

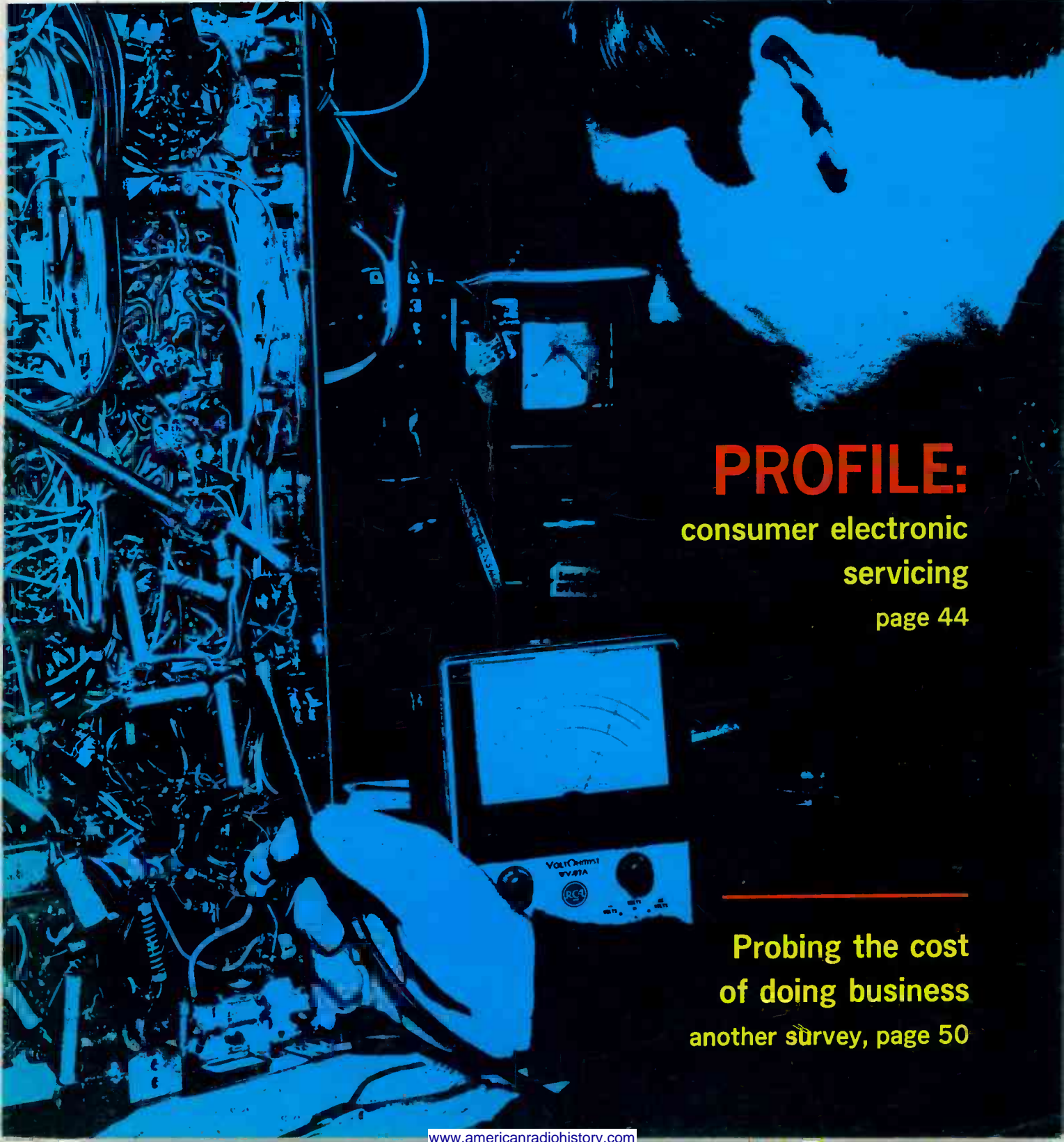
June, 1969 □ 75 cents



A HOWARD W. SAMS PUBLICATION

# Electronic Servicing

Formerly PF Reporter



**PROFILE:**  
consumer electronic  
servicing  
page 44

---

Probing the cost  
of doing business  
another survey, page 50

# The name of the game was hide and seek.

The good color picture hides. The viewer looks for it. And sometimes it takes quite a while to find. The good sound drifts, and between rotor

and tuning dial the search for a perfect stereo balance begins again.

Well now all that time-wasting and bother is over. Because CDE invented the Autorotor™ system. It's more than an ordinary rotor. Buttons are easily set for clear, bright, perfect color pictures. And pure stereo sound. There are five and they allow you to pre-set 10 to 15 channels. Leave one channel and whenever you choose to return to it, just press the button again.

CDE's famous heavy-

duty Bell Rotor gives you high repeatability and no antenna drift. It's an all-solid-state, silent operation. The Autorotor system's precision is within 1° and combining it with pushbutton electronic control, not mechanical control, makes it today's most advanced rotor.

CDE took another step forward in the Autorotor control design. They had William Snaith, of Loewy-Snaith, world famous designers, create the Autorotor console. He made it attractive. Made it so you can place it on a table top or shelf without it being an eyesore.

This is the story you can tell your customers to sell the top-of-the-line in rotors. The latest advance from the quality house of rotors — Cornell-Dubilier.

For complete information on new Autorotor write:



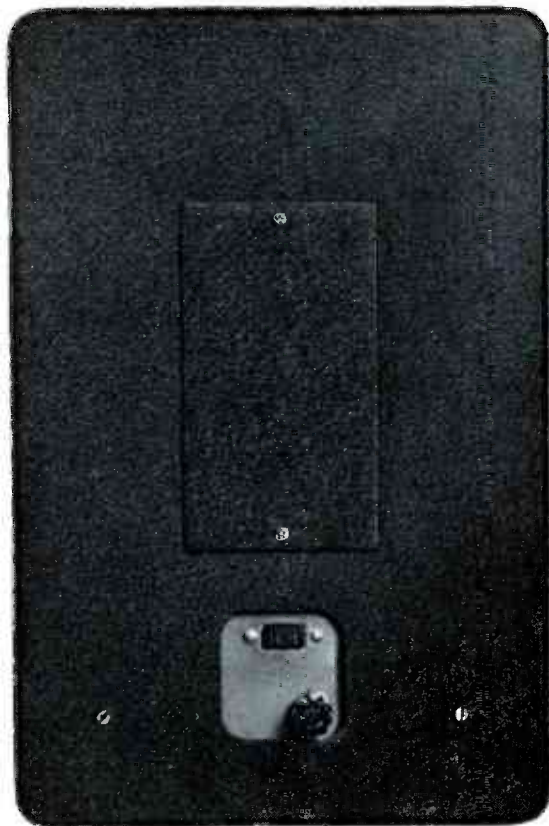
Circle 1 on literature card

**CDE** **CORNELL-DUBILIER**

50 Paris Street, Newark, New Jersey 07101  
"Remember to ask what else needs fixing"



# The back.



## The back of our B&K 1450 Oscilloscope/Vectorscope put us in front.

Notice the back. Clean, isn't it? That's because it's the back of the only oscilloscope/vectorscope with *front vector inputs and controls*.

Now you can troubleshoot with this one instrument as an ultra stable oscilloscope; or as a vectorscope with this important *exclusive* feature: the inputs are amplified! With the control available up *front*, you can troubleshoot at high level (the output of the color amplifiers), or at low level from the demodulator.

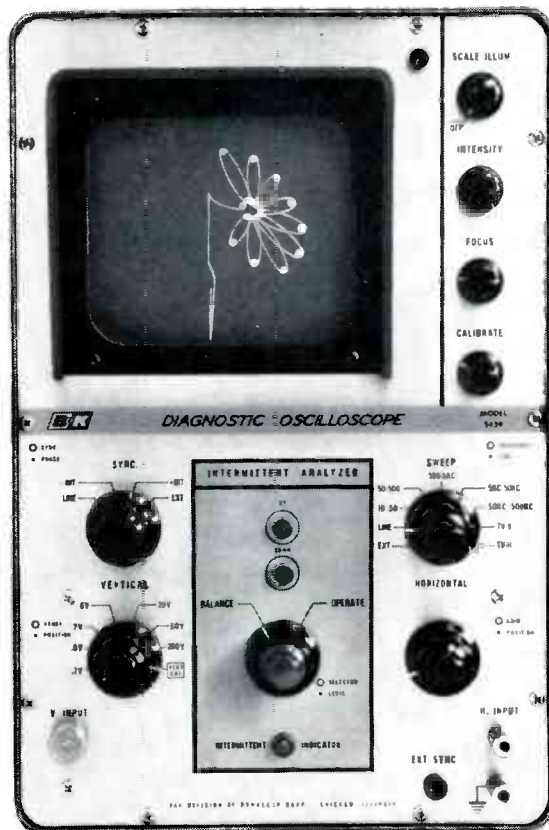
The 1450 shows vector patterns exactly as specified by color TV manufacturers. It also permits direct reading of peak-to-peak voltages from *two calibrated scales*. (Simply switching to the range you want lights up the appropriate scale.)

Any way you look at it, the 1450 Oscilloscope/Vectorscope means greater shop efficiency, more time for profit-making calls, and a lot more mileage from a very fine diagnostic oscilloscope. All from B&K—the company that put an end to ordinary test equipment (the kind that puts an end to your patience).

Of course, we've tried to show you our good side—both of them. Now it's up to *you* to side with *us*. See your B&K distributor soon—or drop us a note for more detailed information.

**Model 1450. Net: \$279.95.**

# The front.



## The front (and inside) of our B&K 1450 Oscilloscope/Vectorscope keeps us there.

Our scope has an exclusive diagnostic device called the *intermittent analyzer*, with electronic memory and optional audio/visual remote alarm (model MON-45).

With this sophisticated detection-reporting system, elusive intermittent conditions can be caught and identified in your absence. Just pre-set one control: if the stage is faulty, it will eventually be detected. And when it is, the intermittent indicator on the 1450 will turn on and stay on until you return from service calls.

All and patterns are locked in at any signal level or frequency by *automatic synchronization*.



Product of DYNASCAN CORPORATION 1801 W. Belle Plaine, Chicago, Illinois 60613

**B&K puts an end to test equipment. We've developed "Silent Partners."**

Circle 2 on literature card

# Electronic Servicing

Formerly PF Reporter

*in this issue...*

- 12 **Dale's Service Bench**—Allan Dale discusses the operation and servicing of speed regulation circuits in auto stereo tape units.

---

- 16 **TV Antenna System Or Receiver Defect?** This analysis of antenna-system parameters, receiver defects and the causes of common problems will help you answer this question. **by Bruce Anderson.**

---

- 30 **Color TV Setup—The Professional Way, Part 2.** Tips on purity, gray-scale tracking and convergence procedures. **by Wayne Lemons.**

---

- 44 **Profile of the Electronic Servicing Business.** Tabulated results of the fact-finding survey conducted in the January '69 issue of ELECTRONIC SERVICING.

---

- 50 **Survey of 1968 Cost of Doing Business.** Help us provide you with more facts about your industry. The tabulated results of this survey will enable you to compare your cost of doing business, labor recovery rate and other operating factors with those of shops of similar size in your geographical area.

---

- 56 **Solving High-Voltage Regulator Problems.** Circuit operation, trouble symptoms and techniques for troubleshooting series- and shunt-type circuits. **by Carl Babcoke.**

## DEPARTMENTS

Electronic Scanner . . . . . 4	Book Review . . . . . 63
Letters To The Editor . . . . . 8	PHOTOFACT BULLETIN . 63
Test Equipment Report . . . . 40	Product Report . . . . . 65
Troubleshooter . . . . . 54	Advertisers' Index . . . . . 67
Antenna System Report . . . . 62	Catalog and Literature . . . 68

Second class postage paid at Kansas City, Mo. and additional mailing offices. Published monthly by INTERTEC PUBLISHING CORP., 1014 Wyandotte St., Kansas City, Mo. 64105. Vol. 19, No. 6. Subscription rates \$5 per year in U.S., its possessions and Canada; other countries \$6 per year.

Copyright, 1969, Howard W. Sams & Co., Inc. All Rights Reserved. Material may not be reproduced or photocopied in any form without written permission of publisher.

### EDITORIAL

GEO. H. SEFEROVICH, Director  
J. W. PHIPPS, Managing Editor  
WENDALL BURNS, Business Operations Editor  
CAROLYN TICE, Editorial Production  
MARY WHELAN, Editorial Assistant  
DUDLEY ROSE, Art Director  
LEILA JOHNSON, Assistant Artist

### CONTRIBUTING AUTHORS

Bruce Anderson  
Carl Babcoke  
Allan Dale  
Wayne Lemons  
Robert G. Middleton

### TECHNICAL CONSULTANT

JOE A. GROVES

### EDITORIAL ADVISORY BOARD

LES NELSON, Chairman  
Howard W. Sams & Co., Indianapolis

### CIRCULATION

R. VINCENT WARD, Director  
EVELYN RODGERS, Manager

### ADVERTISING SALES

Kansas City, Missouri 64105  
Tele: 913/888-4664  
E. P. LANGAN, Director  
R. JACK HANCOCK, Manager  
S. F. WILSON, Production

### REGIONAL ADVERTISING SALES OFFICES

Indianapolis, Indiana 46280  
ROY HENRY  
2469 E. 98th St.  
Tele: 317/846-8561

New York, New York 10019

CHARLES C. HORNER  
3 W. 57th St.  
Tele: 212/688-6350

Mission, Kansas 66208

JAKE STOCKWELL  
C. H. Stockwell Co.  
4916 W. 64th St.  
Tele: 913/722-4417

Los Angeles, California

THE MAURICE A. KIMBALL CO., INC.  
2008 Carson St., Suites 203-204  
Torrance, California 90501

San Francisco, California 94104

THE MAURICE A. KIMBALL CO., INC.  
580 Market Street, Room 400  
Tele: 415/392-3365

London W. C. 2, England

JOHN ASHCRAFT & CO.  
12 Bear Street  
Leicester Square  
Tele: 930-0525

Amsterdam C. Holland

JOHN ASHCRAFT & CO.  
W.J.M. Sanders, Mgr.  
for Benelux & Germany  
Herengracht 365  
Tele: 020-240908

Paris 5, France

JOHN ASHCRAFT & CO.  
9 Rue Lagrange  
Tele: 033-2087

Tokyo, Japan

INTERNATIONAL MEDIA  
REPRESENTATIVES LTD.  
1, Shiba-Kotohiracho, Minatoku  
Tele: 502-0656



ELECTRONIC SERVICING (with which is combined PF Reporter) is published monthly by Intertec Publishing Corp., 1014 Wyandotte Street, Kansas City, Missouri 64105.

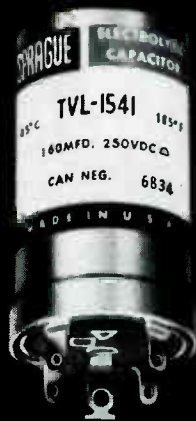
Subscription Prices: 1 year—\$5.00, 2 years—\$8.00, 3 years—\$10.00, in the U. S. A., its possessions and Canada.

All other foreign countries: 1 year—\$6.00, 2 years—\$10.00, 3 years—\$13.00. Single copy 75¢; back copies \$1.



Robert E. Hertel, Publisher

Intertec Publishing Corp.  
Subsidiary of Howard W. Sams & Co., Inc.



## THIS CAPACITOR IS AN EXACT REPLACEMENT IN 27 DIFFERENT MAKES OF COLOR TV SETS

Why settle for "nearly-right" substitutes? 2,365 different ratings in the Sprague TWIST-LOK® Line give you the exact capacitors you need to meet the exacting requirements of Color TV.

Get Replacement Capacitor Manual K-109 from your Sprague distributor, or write to Sprague Products Co., 105 Marshall St., North Adams, Mass. 01247.

**THE BROAD-LINE PRODUCER OF ELECTRONIC PARTS**

*Circle 3 on literature card*



'Sprague' and '®' are registered trademarks of the Sprague Electric Co.

June, 1969/ELECTRONIC SERVICING 3

## Speedy solutions to servicing problems from **LECTROTECH**



### V6-B Color Bar Generator

The Finest Color Bar Generator At Any Price

- Line operated — no dead batteries to worry about
- Fully voltage regulated • All solid state
- Operates on channels 3, 4, or 5
- Red, Green, Blue Gun Killers
- All patterns — crosshatch, dot, color bars, etc.
- Exclusive dial-a-line • Adjustable dot size
- All cables permanently attached
- Fully enclosed cable compartment
- Compact: Size 7 7/8" x 3 1/2" x 9"

NET \$99<sup>50</sup>



VISUAL  
DISPLAY

### V-5 Vectorscope Indicator

For Use With Any  
Standard 10 Bar Keyed Rainbow Color Generator

- Checks and aligns all color circuits
  - Checks and aligns bandpass amplifier circuits
  - Eliminates weak and smeared color
  - Accurately and quickly aligns demodulator to any angle — 90°-105°-115° • 3" cathode ray tube
  - Pinpoints trouble to specific circuits
  - Accurately adjusts color sync circuits
  - Accurately adjusts tint control range.
  - Compact: Size 7 3/8" W. x 4 1/4" H. x 7 5/8" D.
- Complete with leads and copy of Wayne Lemon's Book, "Color TV Servicing with a Vectorscope."

NET \$79<sup>50</sup>

FULL ONE YEAR WARRANTY ON BOTH UNITS



See your distributor or write DEPT. ES-6

**LECTROTECH, INC.**

4529 North Kedzie Avenue, Chicago, Illinois 60625

Circle 4 on literature card

# electronic scanner

news of the industry

#### Japan Develops All-IC Color Portable

Kansai Electronic Development Center, located at Osaka, Japan, has completed development of a prototype of an all-IC 16-inch portable color television receiver, according to a recent report in **Home Furnishings Daily**.

The prototype employs 22 integrated circuits—half monolithic and half hybrid—and 174 other components.

Although the prototype has been completed, it will be some time before the receiver is ready for commercial production. Improvement of some of the integrated circuitry was given as the reason for the delay.

Other recent developments in TV design include a 9-inch flat-screen b-w TV, exhibited by Panasonic at the Electronics Engineers (IEEE) Show in New York in March, and the Sony Trinitron (one gun) color TV, also exhibited at the IEEE Show in March of this year.

#### C.E.T.'s International

The National Electronic Associations' (NEA) Certification Committee issued Certified Electronic Technician (C.E.T.) certificates to electronic technicians in several other countries during the months of March and April of this year.

Countries now having C.E.T.'s include the U.S., Guam, Canada, South Vietnam, Argentina and Germany. Other countries in which technicians are attempting to qualify for C.E.T. certificates are Brazil, Spain, Puerto Rico and Mexico.

To become registered by NEA as a C.E.T., a technician must successfully complete a 126-question technical test administered under the supervision of NEA's C.E.T. Committee. In addition, the applicant must have evidence of a combination of 4 years of schooling and experience in servicing consumer electronics products.

#### RCA Produces 50 Millionth TV Picture Tube

RCA has announced the production of their 50 millionth TV picture tube.

According to H. R. Seelen, Division Vice President and General Manager of the RCA TV Picture Tube Division, during the past 25 years, RCA has made over 37 million black-and-white picture tubes and nearly 13 million color picture tubes. Fifty million picture tubes represent a quantity sufficient to equip more than 60 per cent of the TV sets currently in use throughout the U.S.

Mr. Seelen stated that RCA currently produces more than 142 different types of black-and-white TV picture tubes ranging in size from an 8-inch to a 23-inch type, and 28 different types of color picture tubes.





# OVERHAUL

# \$975

## GUARANTEED for 1 Year

### OVERHAUL \$9.75 • REPLACEMENT TUNERS...\$10.45

Nine-seventy-five buys you a complete tuner overhaul—including parts (except tubes or transistors)—and absolutely no hidden charges. All makes, color or black and white. UV combos only \$15.

Guaranteed means a full 12-month warranty against defective workmanship and parts failure due to normal usage. That's 9 months to a year better than others. And it's backed up by the only tuner repair service authorized and supervised by the world's largest tuner manufacturer—Sarkes Tarzian, Inc.

Four conveniently located service centers assure speedy in-and-out service. All tuners thoroughly cleaned, inside and out... needed repairs made... all channels aligned to factory specs, then rushed back to you. They look—and perform—like new.

SEND ORDERS FOR UNIVERSAL AND CUSTOMIZED REPLACEMENT TUNERS TO OUR OFFICE IN INDIANAPOLIS.

Prefer a universal replacement? Sarkes Tarzian will give you a universal replacement for only \$10.45. This price is the same for all models. The tuner is a new tuner designed and built specifically by Sarkes Tarzian for this purpose. It has memory fine tuning—UHF plug-in for 82 channel sets—universal mounting—hi-gain—lo-noise.

#### ORDER TUNERS BY PART NUMBER, AS FOLLOWS:

Part #	Intermediate Frequency	AF Amp Tube	Osc. Mixer Tube	Heater
MFT-1	41.25 mc Sound 45.75 mc Video	6GK5	6LJ8	Parallel 6.3V
MFT-2	41.25 mc Sound 45.75 mc Video	3GK5	5LJ8	Series 450 MA
MFT-3	41.25 mc Sound 45.75 mc Video	2GK5	5CG8	Series 600 MA

Prefer a customized replacement tuner? The price will be \$18.25. Send us the original tuner for comparison purposes, also TV make, chassis and model numbers.



#### TUNER SERVICE CORPORATION FACTORY-SUPERVISED TUNER SERVICE

<b>MIDWEST</b>	817 N. PENNSYLVANIA ST., Indianapolis, Indiana (Home Office)	TEL: 317-632-3493
<b>EAST</b>	547-49 TONNELE AVE., Jersey City, New Jersey	TEL: 201-792-3730
<b>SOUTH-EAST</b>	938 GORDON ST., S. W., Atlanta, Georgia	TEL: 404-758-2232
<b>WEST</b>	SARKES TARZIAN, Inc. TUNER SERVICE DIVISION 10654 MAGNOLIA BLVD., North Hollywood, California	TEL: 213-769-2720

WATCH FOR NEW CENTERS UNDER DEVELOPMENT

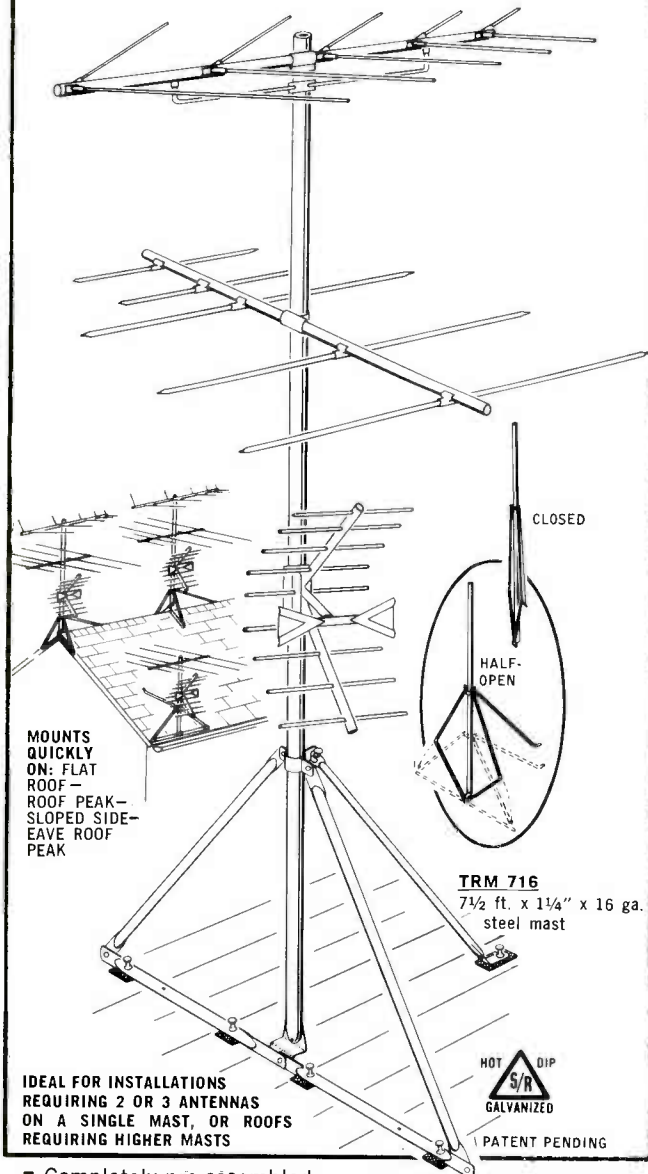
Circle 5 on literature card

NEW!  
AVAILABLE ONLY FROM

*South River*

HEAVY-DUTY • TV/FM ANTENNA

# 7½ ft. TRI-MOUNT ROOF TOWER



MOUNTS QUICKLY ON: FLAT ROOF - ROOF PEAK - SLOPED SIDE-EAVE ROOF PEAK

TRM 716  
7½ ft. x 1¼" x 16 ga.  
steel mast



PATENT PENDING

IDEAL FOR INSTALLATIONS REQUIRING 2 OR 3 ANTENNAS ON A SINGLE MAST, OR ROOFS REQUIRING HIGHER MASTS

- Completely pre-assembled; shipped folded; opens like an umbrella
- Self-supporting antenna mast roof mount
- Single-wing nut secures tri-mount in desired mounting position
- Complete with hardware including special mounting nails and roof-sealing pitch patches
- No guying required
- Made of heavy-gauge, hot-dip galvanized, rust-proof steel mast
- Also available in kits with wire, insulators, etc.

**SEND FOR COMPLETE DATA SHEET**

SOLD THROUGH DISTRIBUTORS

**SOUTH RIVER METAL PRODUCTS CO., INC.**

SOUTH RIVER, NEW JERSEY 08882 / (201) 254-5252

Circle 6 on literature card

## New Director of NEA's Apprenticeship and Training

Charles Cave, C.E.T., 7902 Bardstown Rd., Louisville, Kentucky, has been appointed to the position of Director of the National Electronic Associations' (NEA) Apprenticeship and Training activities.

Mr. Cave has 14 years experience as a home electronics service technician and is presently an instructor at Ahrens Trade School in Louisville. He is a member of both the Louisville and Kentucky Electronic Technicians Associations and presently is vice president of the states association.

NEA's Apprenticeship and Training Committee is comprised of 39 technicians. Most are shop owners. One is a wholesale electronic parts distributor, 7 are employee technicians, 6 are full-time instructors at public or private vocational schools or colleges and 2 are association executives.

NEA presently is registering trainees as apprentices and recommends training courses for them. NEA's Apprenticeship Program is registered with the U. S. Labor Department.



### Voice-Operated Typewriter

The experimental voice-operated typewriter shown here can be operated at 20 words per minute by orally "dit-dahing" Morse-code sounds into the machine's microphone.

The device, still under development by a British division of International Telephone and Telegraph Corporation, is being studied as an aid to the physically handicapped. No plans for production are foreseen in the near future. ▲

Coming next month . . .

- VSM Alignment of Color TV
- Solving "No High Voltage" Symptoms
- Common Tape Recorder Troubles
- Troubleshooting AGC and ACC . . .

and Allan Dale tells why vectorscopes have become popular.



# BUSS QUALITY

## SMALL DIMENSION FUSES and FUSEHOLDERS

FOR THE PROTECTION OF ALL TYPES OF  
ELECTRONIC & ELECTRICAL CIRCUITS & DEVICES

The complete BUSS line of fuses includes dual-element "slow-blowing," single-element "quick-acting" and signal or visual indicating types . . . in sizes from 1/500 amp. up—plus a companion line of fuse clips, blocks and holders.

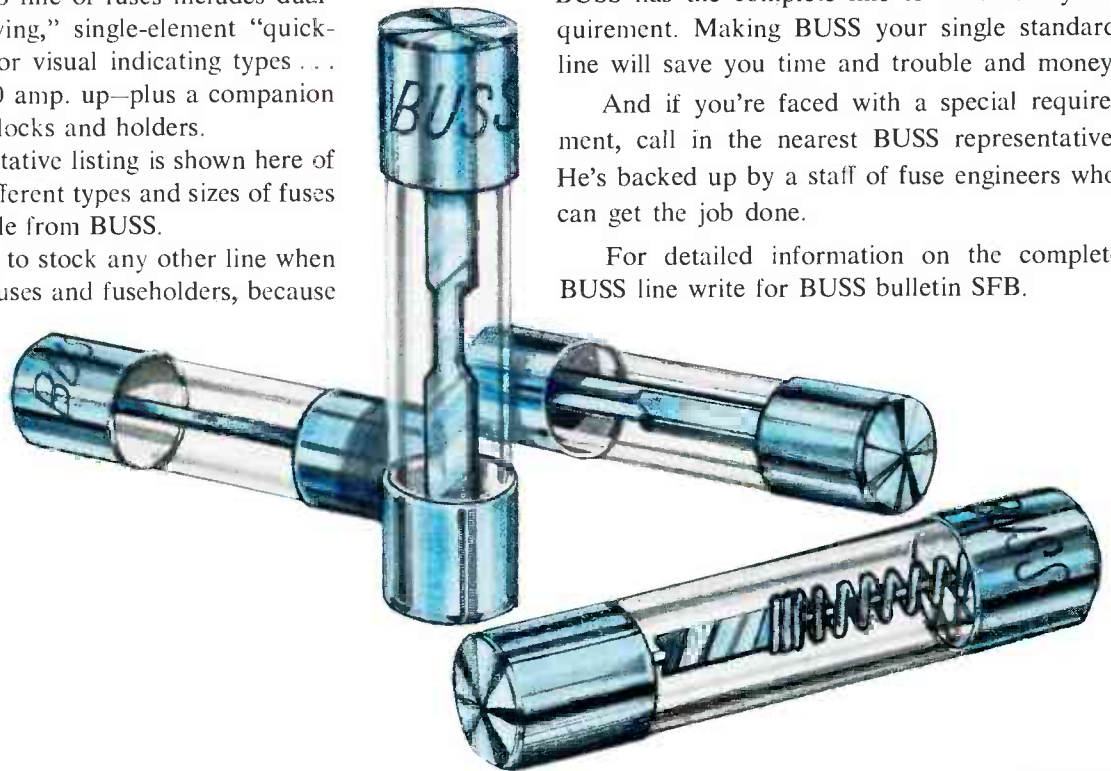
Only a representative listing is shown here of the thousands of different types and sizes of fuses and holders available from BUSS.

You don't have to stock any other line when you handle BUSS fuses and fuseholders, because

BUSS has the complete line to cover every requirement. Making BUSS your single standard line will save you time and trouble and money.

And if you're faced with a special requirement, call in the nearest BUSS representative. He's backed up by a staff of fuse engineers who can get the job done.

For detailed information on the complete BUSS line write for BUSS bulletin SFB.



 Buss AGX Fast Acting Fuses	 Buss AGC and MTH Glass Tube Fuses	 Fusetron FNM Fibre Tube Fuses	 Fusetron FNA Indicating Fuses	 Buss In-the-Line or Panel Mounted Fuse/Holder	 Buss Panel Mounted Holders	 Buss Screw or Solder Terminal Fuse Blocks	 Buss Porcelain Base Fuse Blocks
 Buss AGC Glass Tube Fuses	 Buss Indicating Fuses	 Buss Sub-miniature Fuses and Holders	 Tron Sub-miniature Pigtail Fuses	 Buss HPC Holders	 Buss Lamp Indicating Holders	 Buss Silicon Rectifier Fuse Blocks	 Buss Indicating Aircraft Fuses
 Fusetron MDL Fuses	 Buss ABC Ceramic Tube Fuses	 Buss GMT Fuse and HLT Holder	 Buss High Voltage Fuses	 Buss Space Saver Holders	 Buss Shielded Holders	 Fusetron ACK Stud Mounted Fuses	 Limitron KTK High Interrupting Capacity Fuses
 Buss GJV Pigtail Fuses	 Buss SFE Standard Fuses	 Fusetron Type N Fuses and Holders	 Buss In-the-Line Holders	 Buss HLD Visual Indicating Holders	 Buss Signal Fuse Blocks	 Tron Rectifier Fuses	 Buss Miniature Glass Tube Fuses

**BUSSMANN MFG. DIVISION, McGraw-Edison Co., ST. LOUIS, MO. 63107**

Circle 7 on literature card

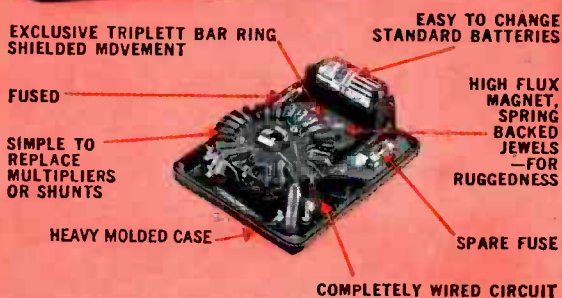


**HIDDEN\*  
QUALITY**

**MODEL 630 V-O-M**



Standard  
Of the  
Industry  
PRICE†  
\$61.00



**FACTS MAKE FEATURES:**

- 1** One selector switch minimizes chance of incorrect settings and burnouts.
- 2** 4.4 ohm center scale, reads from 0.1 ohm up to 100 megohms resistance in 4 ranges.
- 3** 20,000 ohms per volt DC sensitivity; 5,000 AC.

Attention to detail makes the Triplet Model 630 V-O-M a life-time investment. It has an outstanding ohm scale; four ranges—low readings .1 ohm, high 100 megs. Fuse affords extra protection to the resistors in the ohmmeter circuit, especially the X1 setting, should too high a voltage be applied. Accuracy 2% DC to 1200V. Heavy molded case.

DON'T FORGET TO ASK 'EM "WHAT ELSE NEEDS FIXING?"

†630A same as 630 plus 1½% accuracy and mirror scale only \$71.00

**TRIPLETT ELECTRICAL INSTRUMENT COMPANY, BLUFFTON, OHIO**

THE WORLD'S MOST COMPLETE LINE OF V-O-M'S.  
AVAILABLE FROM YOUR TRIPLETT DISTRIBUTOR'S STOCK.

**letters to the editor**

**Degrading To Technicians?**

The phrases "charges for labor" and "anything else needs fixing" degrade a good technician. We do not run "fix-it" shops and we don't dig ditches, which these terms imply.

How about using the following terms in place of the two mentioned previously:

"Do you have other equipment that requires technical service?"

"Charges for professional or technical services."

Glenn Thorn

Mr. Thorn, I completely agree with the basis of your remarks; everyone connected with the electronic servicing business should make every effort to improve the public's image of the business and its members. I believe that much improvement has been accomplished, and continued improvement will result from the conscientious efforts of technicians such as you. However, I do not believe that the term "charges for labor" is degrading, particularly when used in either written or oral communications between members of the same business.

The term "charges for professional or technical services" could be construed to mean both the cost of replacement parts, the cost of time diagnosing the trouble and the time spent replacing the defective part(s); this term does not differentiate between the various elements of the total cost of restoring a defective item to normal operation. I do not believe that a term or phrase should be used if it does not have a practical application and a specific, clear meaning.

The term "anything else needs fixing" is part of a slogan coined by the Electronics Industry Association (EIA) to encourage technicians to seek out additional business. I do not believe that there is anything unhealthy or degrading in either the slogan or its intended purpose.

I have never heard a member of the medical profession complain because someone said he "fixed", "repaired" or "set" a broken leg or "sewed-up" a laceration. I've heard doctors themselves use these terms when talking to patients, and I doubt that the patient thought less of the doctor because of the terms he used to describe his work—it was not **what** he called his work that counted, only **how well** he did it.

I believe that the title of a profession or skill should be accurate and descriptive, and one which an individual can be proud of; but true pride is not a product of labeling, it is a product of accomplishment. In my opinion, an individual who services electronic products should be called an "electronic technician", and not because it is "high sounding" but because it is an accurate description of the individual's occupation. And in my opinion, the public's image of an "electronic technician" is dependent, for the most part, on how proficient and honest he is and, to a lesser degree, his personal appearance and bearing. It is very doubtful

← Circle 8 on literature card



# *I'm glad you asked that question...*

Who offers the most profit in tuner service? They tested us and learned:

Would you believe PRECISION TUNER SERVICE does?

If you're one of our thousands of long-time customers, you've already had it proven to you DAY AFTER DAY.

But, if you're not, you'll want to know how we got all those happy customers—(steady, satisfied customers, that is)

- PRECISION TUNER SERVICE is dependable . . . quality work . . . no complaints . . . just conscientious service!
- PRECISION TUNER SERVICE uses only ORIGINAL PARTS . . . no home-made or make-do inferior merchandise! (This is why we charge extra for major parts!) You get your tuner back in ORIGINAL EQUIPMENT condition.
- PRECISION TUNER SERVICE is fastest! Speedy 8-hour service . . . every time. No phone calls. No wondering.
- PRECISION TUNER SERVICE is more profitable! The cost is less . . . up to \$5.50 less than other tuner service! Major parts, tubes, transistors charged at net price. UV Combos—\$14.95

**AND NOW FOR EVEN FASTER SERVICE—  
A BRANCH PLANT IN TEXAS AND CALIFORNIA, TOO!**

Why don't you test us and find out?  
Don't make it easy on us . . .

***don't give us a break!  
you get...***

***Fast 8 hr. Service!***  
***\$8<sup>95</sup>***

**1 Yr. Guarantee**

For finer, faster PRECISION TUNER SERVICE,  
send faulty tuner with tubes, shields and all  
broken parts to:



**PRECISION TUNER SERVICE**

one of the **OLDEST** and **LARGEST** tuner service companies in the country

**WEST:** 2325 WALDORF  
TURLOCK, CALIF. 95380  
TEL. 209, 632-2928

**HOME OFFICE:** 1210 S. WALNUT  
BLOOMINGTON, IND. 47401  
TEL. 812, 339-9653

**SOUTH:** 332 W. TYLER  
LONGVIEW, TEX. 75601  
TEL. 214, 753-4334

Circle 9 on literature card

June, 1969/ELECTRONIC SERVICING 9



# NEW Heathkit® Solid-State Color Bar—Dot Generator



Kit IG-28  
Only \$79.95\*

**Advanced Integrated Circuitry  
Delivers 12 Patterns Plus  
Clear Raster . . . No Divider  
Chain Adjustment . . . No  
Flicker, Bounce or Jitter**

- All solid-state construction using Integrated Circuitry
- No divider chain adjustments
- Stable pattern display — no flicker, bounce or jitter
- Produces 12 patterns plus clear raster
- Instant switch selection of all functions
- Exclusive 3x3 display plus standard 9x9 display of all patterns
- Horizontal lines only one raster thick for added accuracy
- Variable front panel tuning for channels 2 through 6
- Variable front panel positive and negative video output
- Front panel negative going sync output
- Two handy AC outlets on front panel
- Built-in gun shorting circuit with lead piercing connectors
- Front panel switchable crystal controlled sound carrier
- Copper-banded transformer to reduce stray fields
- Safe three-wire line cord
- Fast, easy construction with two circuit boards and two wiring harnesses

**Advanced Design.** The new Heathkit IG-28 is one of the most stable, versatile Color and B&W TV service instruments available. In addition to the exclusive Heath "3 x 3" display of patterns illustrated, it also produces the familiar 9 x 9 displays . . . plus a clear raster for adjusting purity without upsetting the AGC. Fifteen J-K Flip-Flops count down from a crystal controlled oscillator to eliminate divider chain instability and adjustment.

**Time-Saving Versatility . . .** gives you front panel tuning for channels 2 thru 6 . . . front panel variable plus and minus video output . . . front panel sync output . . . two convenient AC outlets . . . built-in gun shorting circuits and grid jacks . . . vectorscope capability . . . crystal controlled sound carrier . . . banded transformer to eliminate stray fields . . . zener-regulated power supply . . . safe three-wire line cord . . . fast circuit board-wiring harness assembly. For the versatility you couldn't get before . . . put the new IG-28 on your bench now.

Kit IG-28, 8 lbs. . . . . \$79.95\*

Standard  
9x9 Displays  
plus  
Exclusive  
Heath  
"3 x 3" Display



that the public will be swayed to any noticeable degree by "high sounding" phrases. The day of the medicine man is gone.—the Editor.

## Plea to TV Manufacturers

In your February 1969 issue you asked readers to share their ideas on effective methods for handling color TVs during servicing.

I wish to suggest that if manufacturers would put a removable panel on the bottom of the set, so that you could get at the complete bottom of the chassis, much time and effort in servicing would be saved.

I realize it's hard to teach an old dog new tricks, but I thought maybe people like you could try a little "gentle" persuasion on the manufacturers and stress how much easier servicing would be with a removable panel on all sets, including black-and-white TVs with horizontal chassis.

Ray Burke  
Middleboro, Mass.

## Two-Way Radio in Electronics Field

I enjoy reading your publication and am always waiting for the next month's issue. I am also impressed with the new title of your publication. However, I do not feel like one of your readers about two-way radio being a different field. I feel that two-way radio articles should be in your publication.

The title of your publication covers quite a territory in the electronics field. I feel that every electronic technician, whatever his field, realizes that basic electronics is used in all fields—TV, home, car or two-way radio, computers, stereo, tube and transistor type, FM, AM and Pulse—all are electronics.

I have been in all fields, and I am now in two-way radio. I have been in electronics for about 34 years and have seen the great changes made. Keep up the good work.

Joe J. Stoupa  
Tucson, Arizona

## Current-Electron Flow Theory Clarified

In reference to your answer to Mr. McDaniel's letter (Apr'69) questioning the direction of current flow, I would like to attempt to explain the origin of the two theories.

Several years ago, current was assumed to flow from positive to negative. This theory originated from the flow of ions in an electrolytic solution, made apparent by the resultant deposits of pole material. Many textbooks still refer to this theory of current flow. In fact, the electrical industry still refers to current flow as positive to negative.

The theory which you were taught [negative to positive] should more properly be called the theory of electron flow. This theory is the accepted standard in the electronics industry. As my job involves both electrical and electronics work, reference material sometimes requires considerable study to determine

**HEATH COMPANY, Dept. 25-6**  
Benton Harbor, Michigan 49022

Please send my FREE 1969 Heathkit Catalog.

Enclosed is \$\_\_\_\_\_ plus shipping.

Please send model (s) \_\_\_\_\_

Name \_\_\_\_\_

Address \_\_\_\_\_

City \_\_\_\_\_ State \_\_\_\_\_ Zip \_\_\_\_\_

Prices & specifications subject to change without notice.  
Mail order prices; F.O.B. factory.

TE-201

Circle 10 on literature card

which theory is in use in any particular text.

Although the theory of electron flow is the standard in the electronics industry, some "old hands" still refer to the current flow theory.

Wayne W. Shearer, Jr.  
Pinedale, Wyoming

Thank you, Mr. Shearer, for pointing out the opposing theories of current flow and electron flow. I guess I'll stick with electron flow, although both theories have their positive and negative points (sorry, couldn't resist it).—the Editor

#### Information Needed

I need a schematic or wiring diagram for Schaub Lorenz Touring T50-T60 Radio or the address of the manufacturer. If somebody can help me, I will be very grateful.

E. Cardona  
Apeninos 633  
Puerto Nuevo  
Puerto Rico

We have a McMurdo sweep generator, Model 911, range 2-226 MHz. The manufacturer is McMurdo Silver Co., Inc., Hartford, Conn. We intend to use it only for alignment of FM radios. We need the manual or, at least, a schematic. Return of the original is assured.

Rev. Henry Preneta  
857 Kenneth Ave.  
New Kensington, Pa.  
15008

I would appreciate any assistance you might be able to give me in locating a 12FR8 receiving tube. The tube is used in a Ford Auto Radio Model 12 BU. I have checked with several distributors and been informed that the tube is no longer made. If the tube is no longer made, is it possible there may be a solid state device that can be substituted for it?

Dennis Murphy  
Minneapolis, Minn.

The 12FR8 is listed in Thor Electronics Corp. catalog. Price is \$2.45. Write to:

Thor Electronics Corp.  
741 Livingston St.  
Elizabeth, N.J. 07207

I need a schematic and operating instructions for a Weston Model 772, Type I Analyzer. I have written to the manufacturer, who stated that they have done away with all publications for obsolete equipment. Perhaps a reader of ELECTRONIC SERVICING has a schematic of this unit that he is willing to share.

George A. Homa  
436 South Middle St.  
Frackville, PA 17931 ▲

You're making money in electronics now.

## RCA Offers 4 Ways to Make More.

Study at home...set your own pace.

RCA Institutes has an easy approach to bring you bigger earnings.



#### COLOR TV:

During this course you'll perform over 50 experiments—and receive all parts and instructions to build your own color TV.

The cost of the Color TV Kit is included in the tuition—in both the beginner's program and the advanced course in color TV servicing. (Picture tube optional)

Course is based on the latest receiver circuitry and equipment.



#### SOLID STATE TECHNOLOGY

New courses include the latest findings and techniques in this field. Information you must have if you are to service the multitude of solid state instruments and devices used in TV, Digital, and Communications equipment.

#### FCC LICENSE TRAINING:

Choose the course for the FCC License you want: third, second or first phone. If you need basic training first, apply for the complete License Training Program. Get your License—or your money back.

#### CATV TRAINING:

You'll receive two comprehensive lessons, covering the practical phases of CATV systems in either the Television Servicing or Communications courses.

Licensed by New York State Education Department. Approved for Veterans. Accredited Member National Home Study Council.

# RCA

MAIL THE COUPON NOW FOR COMPLETE INFORMATION.

RCA INSTITUTES, Inc., Dept. PF-69  
320 West 31st Street, N.Y., N.Y. 10001

Please rush me FREE illustrated catalog. I understand that I am under no obligation, and that no salesman will call.

Name \_\_\_\_\_ Age \_\_\_\_\_  
(please print)

Address \_\_\_\_\_

City \_\_\_\_\_

State \_\_\_\_\_ ZIP \_\_\_\_\_

Circle 11 on literature card

# Speed regulation in auto stereo tape

## Circuit operation and quick-servicing techniques

■ For this first of what will be a monthly department, I chose a topic I've heard several technicians talk about. The motors in automobile stereo tape machines get one heck of a beating. They take shaking, dusting, vibrating, overvoltage, undervoltage—plenty of abuse.

Their most difficult job is to maintain accurate speed. Some operate at 1800 rpm, and some at 3000. In either case, constant speed is important. Otherwise, the playback has wow and the pitch isn't true. A few models don't have any way to regulate speed, but most do. The regulator may only keep voltage steady for the motor, or it may actually detect the speed of the motor and develop a correction whenever it varies. You can service either kind easily when you understand them.

### Voltage-Type Regulators

Any series-type transistor voltage regulator works well for this. However, Lear-Jet machines use a sophisticated arrangement (Fig. 1) that does a pretty good job of keeping the voltage steady under many conditions.

First I'll give you a brief explanation of how it works. You'll understand it even better when I describe how you test it. Technicians are wary of this loop-type DC feedback arrangement. The testing procedure

is almost ridiculously simple, once you understand it.

Voltage to drive the motor (M2) is applied through X4 and Q18. Resistor R47 is ground return for the motor. The motor only takes about 5 volts for normal operation. When the system is stabilized at correct speed, 6 volts DC is applied at the positive end of the motor and about 1 volt (across R47) at the negative terminal. Diode X4 has no effect because positive voltage is applied to its anode. I'll explain its purpose later.

Transistor Q18 is a series regulator. How much current reaches the motor depends on Q18's emitter-collector resistance. That is in turn set by base-emitter bias.

Transistor Q17 determines bias on Q18, since its emitter is connected directly to the base of Q18. Whatever affects current through Q17, R42, and R43, controls the bias of Q18—and, therefore, the motor voltage.

Q17 is in turn controlled by Q16. Collector current in Q16 flows through R40, developing a voltage that is applied by R41 to the base of Q17. Bias at the base of Q17 depends, to a small extent, on emitter-base current, because of the comparatively high value of R41.

Bias for Q16 is a function of Q19. Current through Q19 must flow from ground through R47,

through the transistor, and through R39, R38, and X3 to the main power source. Since the base of Q16 goes to the junction between R38 and R39 in this long divider chain, bias for Q16 depends on emitter-collector current in Q19.

Transistor Q19 takes any change in output voltage (sensed across a series of dividers), amplifies it, and passes it to the base of Q16. That changes the voltage at the base of Q17 and then at Q18.

The divider network has two branches: The main leg consists of R44, R4, R45, and R46. Potentiometer R4, because R47 is in series with the motor, balances the motor-control circuit. The thermistor is for temperature compensation, to make sure heat doesn't change the motor speed.

The second branch is R5 and R47; they are in parallel with the portion of R4 that is below the slider, plus R45-R46. R5 is a voltage-output control, although on some sets it is labeled PITCH. The knob comes out underneath the stereo tape unit, and the listener can adjust the speed of the tape—and, therefore, the musical pitch. Usually, you just set it near the center of its rotation and leave it alone. The slider of R5 applies bias to the base of Q19, which, as we've already said, controls the current through R38 and R39. This action



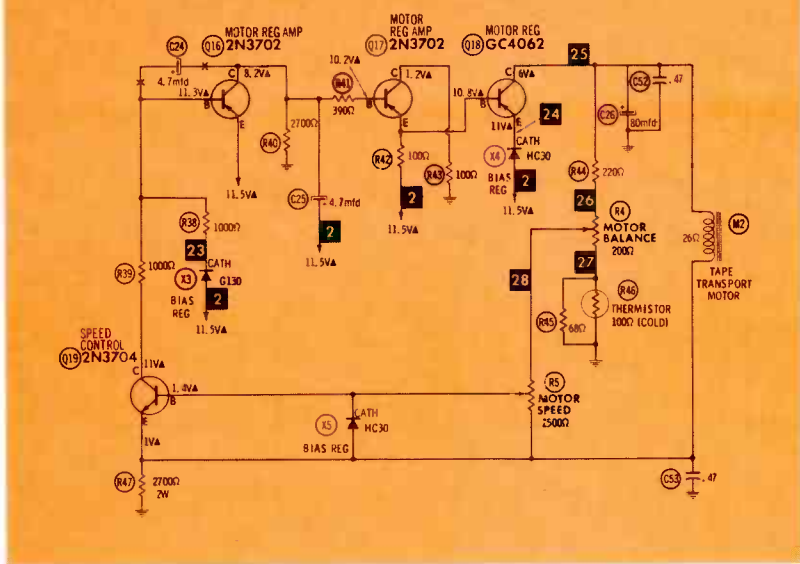


Fig. 1. Speed regulator circuit employed in Lear-Jet auto-stereo tape units.

affects current in Q16 and R40, then Q17-R42, which then lets the right amount of current through Q18.

### Tracking Down Trouble

Here, step by step, is the fastest way to find a fault in this stage:

First, with the set off, disconnect C24, C25, and C26, the electrolytic capacitors. Test them with your ohmmeter. Connect the test leads first one way and then the other. In the direction that charges each electrolytic, you should read 40K or more. Then take loose one lead of C52 and C53; there should be no leakage at all.

If you have any doubts about one of these capacitors, substitute a good one while you make the other tests. DO NOT bridge a new one across an old one. Leave the old one completely out of the circuit.

Likewise, make a quick ohmmeter test of the two diodes. (It's quicker than diagnosing the stage with them in doubt.) Disconnect one end of X3, X4, and X5. Measure them forward and backward with your ohmmeter. The ratio should be 100 to 1 or better, and forward resistance should be less than 25 ohms. If they're okay, reconnect them. If not, replace the bad ones.

Now turn the set on for the remaining tests. Clip your positive voltmeter lead to the collector of

Q18, and the negative lead to ground. The motor-wire terminal is usually handy. Watching the meter, clip a shorting jumper between emitter and base of Q18. This removes bias from Q18 and, therefore, almost blocks conduction. Voltage on the meter should drop almost to zero. If it doesn't, Q18 is probably bad. If the voltage drops, go on to the next step.

Move the positive meter lead to the collector of Q17—across R43. Clip the jumper between emitter and base of Q17. This removes bias and drops conduction in that transistor to nearly zero. With little current in R43, the voltage across it should drop way down. If not, Q17 is probably faulty.

If Q17 reacts normally, move the positive meter lead to its base. Then clip the shorting jumper between the base and the emitter of Q16. Voltage should again drop considerably, because you've removed forward bias from Q16. No current in the transistor means no voltage drop across R40. If the voltage stays the same, no matter what it was to start with, the transistor probably is bad.

At this point, you can also check the stage from Q16's base to the output (collector) of Q18. Just move the meter lead back to the collector of Q18. With the jumper between base and emitter of Q16, voltage should be much higher than with the

jumper removed. If not, one of the parts other than the transistors (which you've already proved okay) is at fault.

If the voltages around Q16 are incorrect, and yet the meter responds as described (collector voltage moving down and up as you connect and disconnect the jumper), suspect R38 or R39. Test both of them before you move to the next step.

Leave the voltmeter across R40. Connect your jumper between the slider of R5 and emitter of Q19. Transistor conduction virtually stops, which also stops current through R38 and R39. This means almost no voltage drops across R38. With the higher positive voltage on Q16, forward bias is virtually gone. Voltage across R40, where your meter is connected, should drop almost to zero. If it doesn't, move the positive test lead to the base. Unclip the jumper and then clip it back. If the voltage at the base of Q16 stays the same, with and without the jumper at the slider of R5 and emitter of Q19, then Q19 may be bad.

Move the positive meter lead to the collector of Q19. If the voltage there stays the same while you clip and unclip the jumper, Q19 is bad for sure.

Now you're ready to check out the voltage-divider sensing network.

Connect your positive voltmeter lead to the positive end of the motor. Notice the value. Now move the lead to the negative end (across R47). Voltage there should be only a volt or so.

Now move the test lead to the slider of R4. Turn the shaft from one end to the other. You should see a distinct change on the meter as you rotate this control. If you don't, the control is bad or R44, R45, or R46 is bad. The voltage reading should not go as high as when the meter is across the motor, nor should it drop to zero. The change of reading should be smooth and steady.

Move the positive meter test lead to the junction of R46 and R4. Hold your hot soldering iron or gun near R46. The voltage should vary upward slowly.

Move the meter test lead to the base of Q19. The voltage should vary smoothly from about 1 volt to 1.5 volts as you turn the control back and forth. You can usually feel any roughness or see it on the meter.

You can make all these tests in less time than it takes to read about them. Go through the whole procedure a couple of times on live equipment, and you'll find this simplified, sure, quick approach is yours to use whenever you need it.

### Vibrating-Contact Regulators

Regulators that use vibrating contacts are truly speed governors. They affect motor voltage the same as does a voltage regulating system, but

sensing is related entirely to the speed of the motor. Both Delco and Motorola use this kind of speed control in their tape players. The circuits are so similar, I'll only explain one of them.

Fig. 2 shows Motorola's arrangement. The transistor is an NPN type that can handle fairly heavy current. Resistor R1 applies bias to the transistor through the closed contacts. When power is applied (from a microswitch that's tripped when the cartridge is inserted), the base voltage heavily forward biases the transistor. Q1 conducts its full rated current, which makes it a perfect ground return for the motor. The motor starts running.

After the motor reaches normal speed—in this model, 3000 rpm—the contacts open by centrifugal force. Forward bias is removed from the transistor, which then acts like an open circuit. The motor no longer has a ground return, so it starts slowing down. When speed drops below 3000 rpm, the switch closes again, and Q1 conducts again. This back-and-forth, on-and-off action of the contacts takes place 400 to 600 times every second. The motor holds steadily at the prescribed speed.

With its ground return made and broken so abruptly, the motor self-inductance can produce a voltage spike that might damage the transistor. To prevent that, a large-value electrolytic capacitor, C2, is bridged across Q1 to protect it. The capacitor absorbs any sudden fluctuation in voltage across Q1.

This circuit is easy to troubleshoot. You can check the motor by momentarily grounding the collector of Q1. You shouldn't leave it grounded, because the motor can take only 5 or 6 volts. However, a jumper for just a second will set the motor to racing, and you'll know it's okay.

Disconnect R1 from the motor (contact) wire. Connect a 150-ohm resistor between collector and base of the transistor. This should start the motor running. If it doesn't, the transistor is probably bad.

Connect your voltmeter to the motor wire where R1 was connected. Disconnect the 150-ohm bias resistor. With the motor stopped,

the meter should read nearly the full applied voltage. If it doesn't, the contacts may be glazed or just not touching.

Reconnect the 150-ohm resistor. When the motor speeds up beyond its usual speed, you should get a low or zero voltage reading at the output of the switch. If it's higher, the vibrating contacts must be stuck or sticky.

The voltages in the diagram are not much help. The method just described tells you more. The electrolytic capacitor should be tested individually. If you substitute it, make sure the old one is out of the circuit.

The Delco transistorized governor controls a speed of 1800 rpm, but it works about the same as the Motorola. There is one Delco regulator in which the vibrating contact shorts out a resistor in the ground return of the motor. This is an older system, but you might run across it.

The best way to test it is to disconnect both leads from the vibrating contacts. Connect your ohmmeter across the contacts; they should be closed—zero resistance. Short out the resistor. That lets the motor run fast, and will open up the contacts after speed gets beyond a certain point; the ohmmeter reads zero. After the speed becomes high, the contacts are not vibrating, because there is nothing to slow the speed down. Don't leave this circuit jumpered more than a few seconds, or you'll destroy the motor.

### What Will Be Next

I hope the subject this month has been really helpful to you. Next month I plan to tell you about something that has done a lot for many technicians who work on color television—the vectorscope. This is a test instrument several say they don't fully understand. Next month I'll explain why a vectorscope is so popular with technicians who do understand.

For the months that follow, drop me a postcard telling me what specific equipment and circuits give you the most servicing grief. I'll dig out the best servicing methods for those that bother you most and write them up in this department. ▲

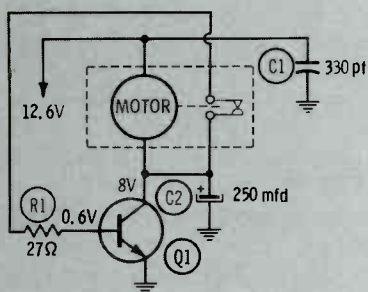


Fig. 2 Motorola auto-stereo tape units use this circuit to regulate motor speed.

# There's a reward

# on their heads.



**FREE:**  
The Copymate Dry Copier, with 20 sheets of copymate paper, with your purchase of the RCA WR-52A Stereo FM Signal Simulator or WO-91C oscilloscope!



The WR-52A Stereo FM Signal Simulator only \$248.00\*

The WO-91C 5-Inch Dual Band Oscilloscope Only \$269.00\*

Now you can own one of the fastest, most accurate trouble-shooters in the East (West, North and South), and receive, absolutely free, the new all-electric Copymate!

Copymate is the portable dry copier that copies anything—... checks, invoices, schematics, photos, your children's drawings and school work—without liquids, chemicals or sprays!

The Copymate, with paper, has a retail value of \$31.94, but you can get it free... Here's how.

Buy the WR-52A or WO-91C between April 15 and July 15. Mail us your warranty card and the blue label on the outside of the carton no later than July 31st and we'll ship the Copymate to you at once, freight prepaid!

Good deal? You know it is.

Mail your card and label to: RCA Electronic Components, Test Equipment Headquarters, Bldg. 17-2, Harrison, N. J. 07029.

\*Optional distributor resale price.

# RCA

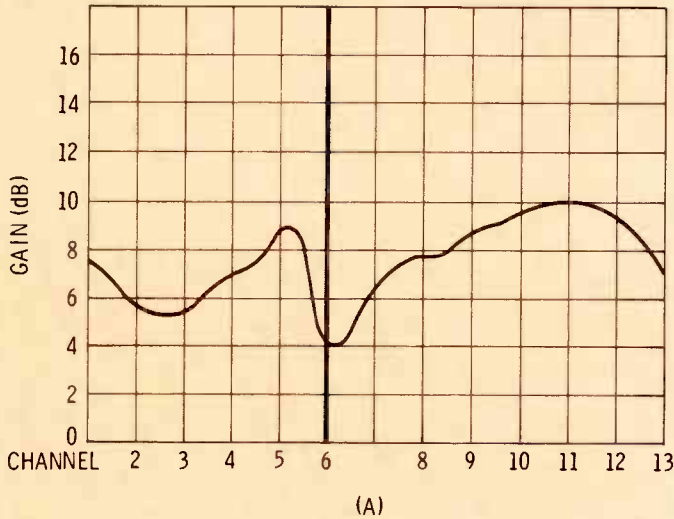
Circle 12 on literature card



# TV Antenna System or

**Trouble Symptoms—their common causes and quick-servicing techniques for uncovering them.**

by Bruce Anderson



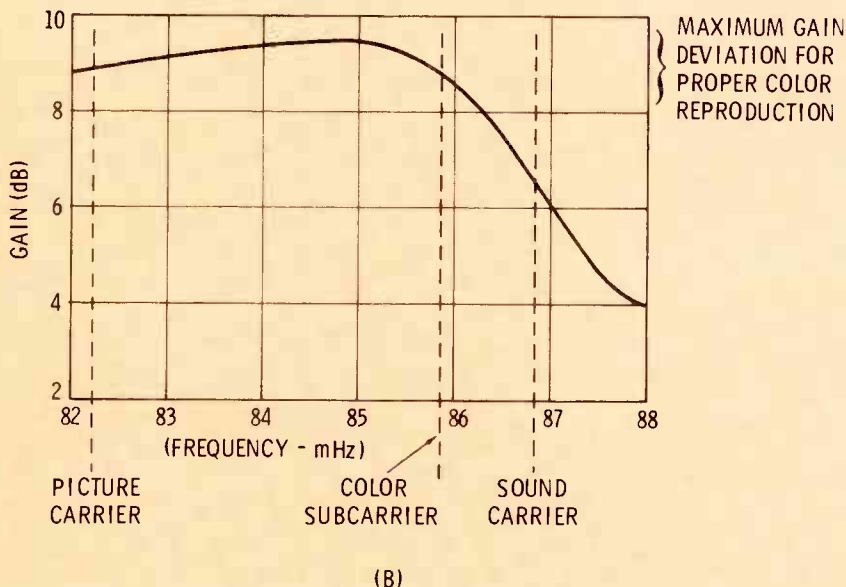
■ Many times, the question of which is the cause of poor reception, receiver or antenna, is a difficult one to answer. Some problems are almost always caused by the receiver itself; others are usually the result of an antenna deficiency; some may be caused by either the receiver or the antenna. This article explores some of these problems and describes techniques and procedures which will help to diagnose the specific symptoms and isolate the trouble to either the receiver or the antenna.

## Antenna System Parameters

The first link in the "receiver chain" is the antenna. The types of antennas are so diverse that a complete description of all of them would be impossible in the space available. A better approach is to describe some of the important characteristics of antennas and how they affect reception under certain conditions. Three important antenna parameters are bandwidth, gain, and directivity.

Bandwidth may be considered in two contexts, within the total TV transmitting spectrum, and within a specific channel. For example, a high-band VHF antenna has a very narrow passband in comparison to the entire VHF spectrum from Channel 2 to Channel 13. On the other hand, its response to all frequencies of a Channel 13 signal may be much flatter than an antenna designed for all the VHF channels, but whose response may actually fall off rather rapidly on Channels 2 and 13.

Some problems which often are associated with poor receiver alignment may be caused by the antenna if its frequency response is ex-



**Fig. 1** Decrease in gain at upper edge of channel passband can result in loss of chroma information. (A) Gain curve of typical all-channel, b-w TV antenna. (B) Excessive drop in gain at upper frequencies of channel 6 passband causes distortion or complete loss of color.

# Receiver Defect?

tremely unequal across a particular channel. To cite some examples, an all-VHF-channel antenna which incorporates an FM trap may have very poor response near the upper edge of Channel 6 (Fig. 1A). This could lead to loss of most of the chroma information, since the chroma signal is nearer the upper limit of the channel than the luminance signal (Fig. 1B). In some instances, the antenna impedance may not be even close to 300 ohms on some channels. This will cause large standing waves, which is another way of saying that the antenna and lead-in exhibit the properties of a resonant circuit. As a result, certain frequency components of a channel may be effectively "tuned out," or reflected energy may cause closely spaced ghosts on the screen resulting in smearing, streaking, ringing, weak or wrong color, etc., all of which are usually associated with poor receiver alignment or improper video bandpass.

Antenna gain and directivity are often thought to be two terms for the same thing, but there is an important distinction. Gain is a measure of the signal received from a properly oriented directional antenna compared to the signal from a non-directional antenna—the more signal from the directional antenna, the higher its gain. Directivity refers to the amount of signal an antenna will pick up when pointed towards the source as opposed to the amount of signal it will pick up from some other direction. In a deep-fringe area, high gain is more important; conversely in an urban area where ghosting is a problem, good directivity is essential. In practice, high gain and good directivity normally occur together, but the directivity pattern may be radically different for two otherwise similar antennas. This can have profound effects on reception.

The lead-in also can have considerable effect on reception. In

general, the two most important criteria for a lead-in are low loss and immunity from the environment, both electrical and mechanical. Again, circumstances will dictate which is more important.

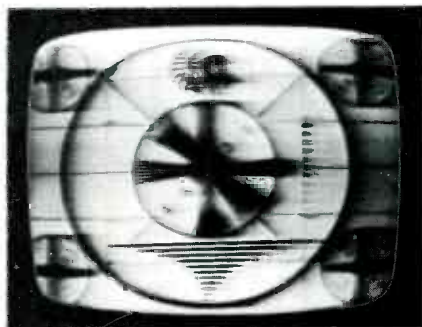
In the early days of television, open (or ladder) line was popular because its loss was extremely low, a necessity when transmitters were weak and receivers were noisy. The difficulties of installing it were tolerated because all the available signal was necessary.

Nowadays, the loss factor is usually less important than ease of installation and immunity from the surroundings. Shielded lead-in, for example, has relatively high loss but it is excellent for use where interference is prevalent or metallic objects cannot be avoided. In other cases, it is used simply because it is more convenient to install, which is perfectly acceptable if the losses can be tolerated.

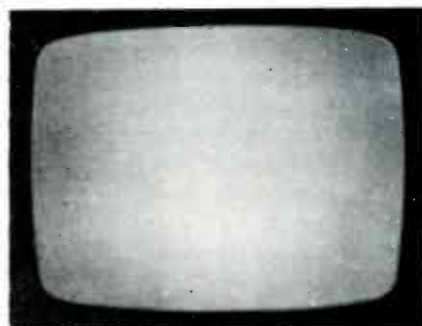
If shielded lead-in is used, it may

be installed with little or no consideration being given to the surroundings. This is not so with unshielded lead-in; careless installation has always led to reception problems; but with the advent of color and UHF, the problems have been greatly accentuated.

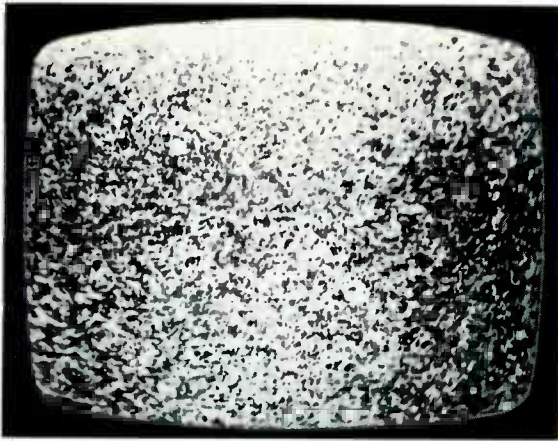
Generally, a color receiver requires somewhat more signal than a black-and-white receiver, for two reasons: The IF bandpass of a color receiver is somewhat more broad in most instances, increasing the inherent receiver noise. (Receiver noise varies directly with bandpass.) Also, noise is more objectionable in a color picture because it is more visible. Because of this, the lead-in should be installed so that losses are held to a minimum. Particularly in dealing with UHF, the line loss increases rapidly if the lead-in becomes wet or covered with dirt. This makes the use of oval (or round), foam-filled line a must. While the use of this type of lead-



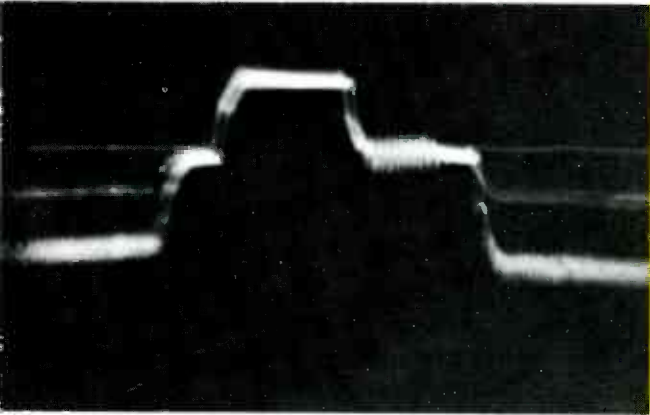
**Fig. 2** Closely spaced ghosts resulting from reflected energy on antenna lead-in reduce the detail in a picture and, if severe enough, can produce the smeared or fuzzy effect illustrated here.



**Fig. 3** No picture and little or no snow indicates that the receiver IF's are not providing adequate amplification. Insufficient or absence of snow is primary clue to cause of this symptom.



**Fig. 4** High-contrast snow on vacant channel is result of excessive gain, and almost always is caused by receiver defect.



**Fig. 5** Normal horizontal sync pulse with color burst on "back porch".

in for VHF is not mandatory by any means, it may improve reception in fringe areas if the atmosphere contains heavy concentrations of moisture, salt, or smog.

Another source of trouble is a high standing wave on the lead-in (high SWR). As mentioned earlier, this may cause the antenna system to become frequency selective; also, it may cause the right edges of objects in the picture to become "fuzzy" or "edgy", as shown in Fig. 2. These effects are the result of a part of the signal "bouncing" up and down the line, because of reflections, and being received later than the principal signal. Actually, a ghost is produced, but since the delay is very short, only a very slight displacement of the video is observed. This problem also is more pronounced with color and UHF reception.

Standing waves are produced whenever the impedance of the antenna system is changed at some point. Routing the lead-in very close to metallic objects is the most frequent cause of the high SWR on the lead-in. Stand-offs which form a metal loop around unshielded

lead-in are no exception—they do cause reflections, particularly on UHF. UHF stand-offs must be used for UHF; they are highly recommended for all installations.

#### Receiver Defects

The receiving section of the television set amplifies the incoming signal, converts it to an intermediate frequency for further amplification, and, finally, separates the intelligence from the carrier.

While the number of specific faults which can develop in the receiving section of a television set is perhaps limited only by the number of components in it, all these receiver faults fall into four general categories:

1. **Insufficient gain.** This means that the tuner and IF amplifiers no longer are capable of amplifying the signal sufficiently. The result is no picture and little or no snow (Fig. 3) or a loss of contrast with little or no snow on vacant channels. These symptoms are seldom, if ever, caused by the antenna.
2. **Excessive noise.** Too much noise will cause even a strong signal to produce a snowy picture. If the

AGC system is working properly, it will increase or decrease, as necessary, the receiver gain until the output of the video detector reaches its design value (if that is possible). Therefore, the amount of snow on a vacant channel is not a good indication of the receiver noise (it is a good indication of the next type of fault). A snowy picture may be caused by either the receiver or the antenna.

3. **Excessive gain.** If the AGC system does not provide sufficient bias, the gain of the receiver will increase. Excessive contrast and poor sync are the usual results. High-contrast snow on vacant channels (Fig 4) also is to be expected. This set of symptoms is caused almost always by the receiver.

4. **Improper bandpass.** If the tuned circuits of the RF tuner, IF, and chroma-bandpass are misaligned, symptoms such as streaking, smearing, ringing, or edge-effect (trailing reversal) are likely. During color reception, the hue or saturation may be incorrect. Careful observation of the horizontal sync pulses at the second detector will often help in diagnosing poor alignment. Fig. 5 shows a normal sync pulse with color burst on the back porch. A wide-band scope with a low-capacitance probe must be used to obtain this waveform. Tilt, overshoot, undershoot, or a tendency toward oscillation at the leading edge of the pulse are all indications of poor alignment.

#### Isolating The Trouble

With but few exceptions (mostly very modestly priced monochrome sets), every television set will produce a snowy raster, even with a short circuit across the antenna terminals. Accordingly, if the symptom is a "weak picture," without evidence of snow (Fig. 6), a good first check is to short the antenna terminals, tune to a vacant channel, adjust for maximum contrast, and check for snow. If none is present, the problem is probably in the receiver rather than the antenna. The



# NEW FINCO®

**HOME ENTERTAINMENT  
DISTRIBUTION WIRING  
SYSTEM DESIGNED FOR  
EASY INSTALLATION**



**PACKAGED IN A  
SELF-SELLING  
DISPLAY.**

HWK-75 75 ohm  
HWK-300 300 ohm

● For Color TV  
— UHF/VHF

● Black &  
White TV

● FM/FM  
Stereo

● Get in on the MATV boom  
in multiple set homes.

● A new business means  
more profits.

● Everything needed to wire a  
home for multiple set reception.

● Your service department can  
easily install this system.



**THE FINNEY  
COMPANY**

34 WEST INTERSTATE STREET  
DEPT. ES-6  
BEDFORD, OHIO 44146

Please send free brochure 20-520 on  
FINCO HOME TV DISTRIBUTION KIT.

Name \_\_\_\_\_

Address \_\_\_\_\_

City \_\_\_\_\_ State \_\_\_\_\_ Zip \_\_\_\_\_

Circle 13 on literature card

amount of snow visible depends on the overall gain of the receiver, and varies slightly from one receiver to another. A little experience will help you to learn what is normal for various receivers.

If the picture is weak but both sound and sync are normal, the problem is likely to be past the sync takeoff point. On the other hand, if sync is critical, it is more likely that the problem precedes the point from which the signal is fed to the sync separator. Naturally, the tubes in the IF strip and tuner are suspect; so is the AGC keyer and the noise inverter.

If tube substitution does not solve this difficulty, a logical first step is to check the signal amplitude at the second detector. Manufacturers' ser-

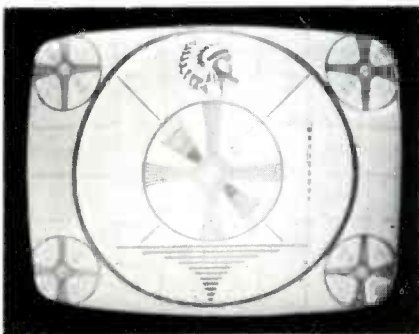


Fig. 6 Weak picture with no evidence of snow.

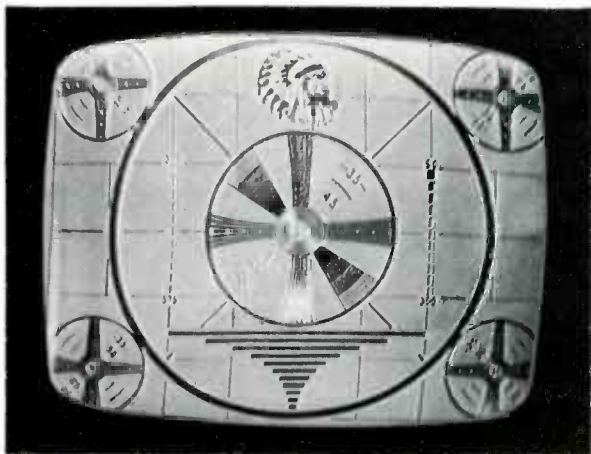


Fig. 7 White outline following black detail in this photo is called edge-effect or trailing reversal, and is usually caused by improper bandwidth of receiver video amplifiers. Closely spaced multiple ghosting caused by antenna-system defect closely resembles this symptom.

vice data or Sams PHOTOFACT information will specify the correct level. If it is too low, the problem is either in the receiver proper or in the AGC system. Again using the service information, determine the fixed bias that is required for alignment, and clamp the AGC to this voltage. If this restores a normal picture, the problem is in the AGC system; otherwise, it is in the tuner or IF.

A snowy picture is unlike a weak picture (which has no snow); it can be caused by either the receiver or the antenna. In deep-fringe areas, complete loss of picture with a snowy raster can result from antenna failure; in other areas, a small amount of video will be visible, even with the antenna disconnected. A fast check of receiver operation can be made with a color-bar generator. Simply connect **both** leads from the generator to **one** of the antenna terminals. This should produce a snowy pattern. A little experimentation will tell you just what to expect from your generator.

Actually, many poor-reception problems can be solved even before you get to the door. Broken lead-ins, antennas with elements missing, misorientation, unshielded lead-in lying in an eave trough, and similar trouble-producing conditions often can be spotted as you approach the house. In other cases,

these failures will not be so evident. If you see from the picture on the antenna system, don't be reluctant to go outside and make a thorough inspection. It is better to do this immediately rather than after removing the cabinet back and trying half-a-dozen tubes.

Some technicians have another technique which works very well. They carry a new, small portable receiver in the service truck. While they are outside checking the antenna, they get it out of its box and bring it back into the customer's house for a final test of the antenna. This works better than a signal-strength meter because the results are obvious to the customer as well as to the technician. Furthermore, it is difficult to sell a signal-strength meter, but a shiny new portable may be hard to get out of the house—after a little low-pressure salesmanship.

Other problems which may be caused by either the receiver or the antenna are ringing and "edge-effect." Actually the two symptoms are slightly different.

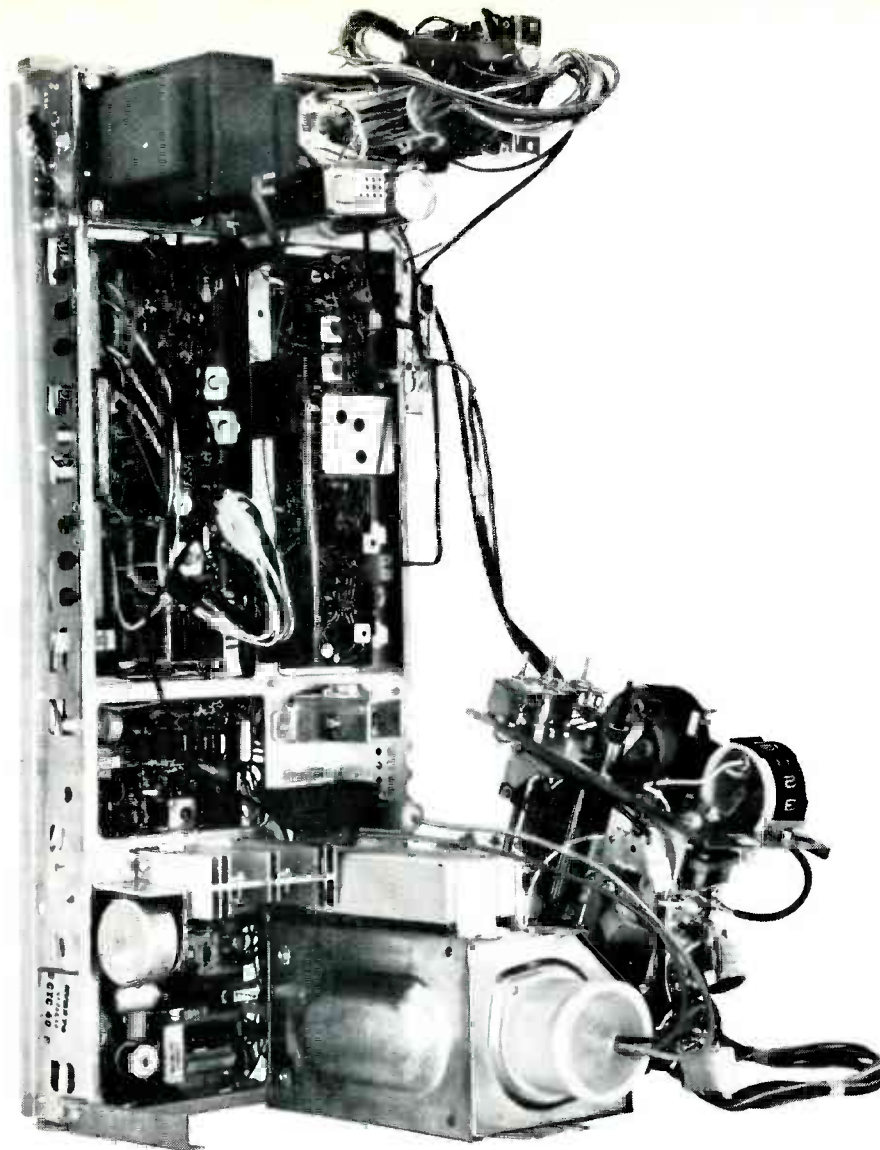
Ringling is caused by a tending toward oscillation and causes a series of closely spaced images to the right of the actual picture on the screen.

Edge-effect, or trailing reversal, is the result of a single half-cycle of ringing: On the screen, a white object is followed by a black outline, and vice versa, as shown in Fig. 7.

Similar in appearance to ringing is multiple "ghosting," which is more prevalent on UHF, and is caused by the presence of several reflecting objects nearly in a straight line between the transmitter and the receiving antenna.

In most instances, these problems can be isolated to either the antenna or the receiver by use of the small portable TV receiver. Be wary, however, when ringing or edge-effect are just perceptible on the customer's set; your portable may not be sufficiently sensitive to





# There's more here than meets the eye.

What you are looking at is RCA's solid-state\* color chassis—the CTC-40. A whole lot went into that chassis. Like fifteen years of technical research. Pioneering in the development of Solid State. And the backing of a national workshop program like nobody else's.

That's where you come in.

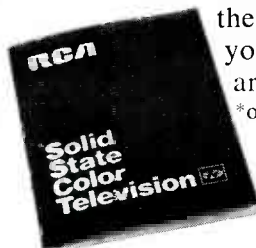
We've written a technical manual on the CTC-40 especially for Electronic Service Technicians. It has color

diagrams, pictures, and everything there is to know about our CTC-40.

You can buy it from your RCA Consumer Electronics Distributor, but there's a better way.

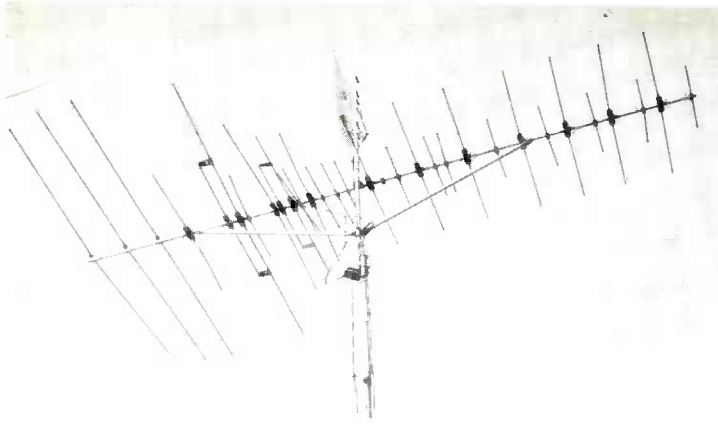
Attend the next RCA Consumer Electronics Distributor CTC-40 Workshop and get the manual free. Our distributor can tell you when it will be held next in your area. See you there.

\*one tube rectifier

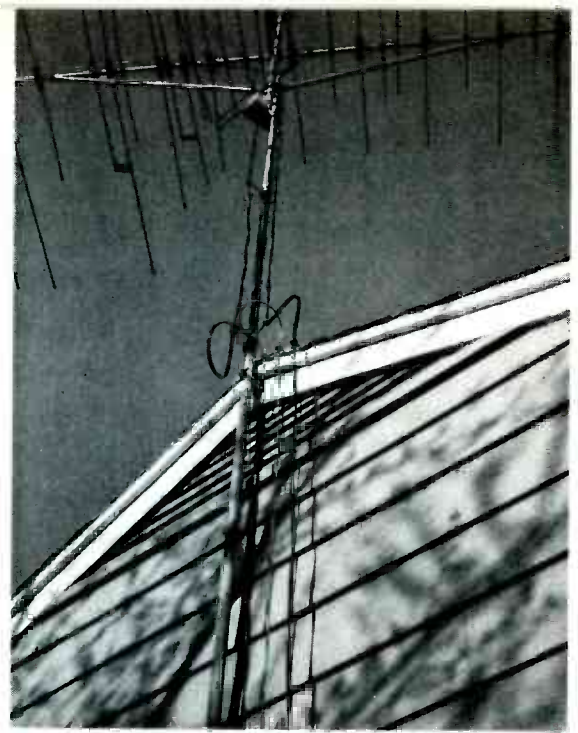


Circle 14 on literature card





**Fig. 8** TV antenna system employing a rotator and separate VHF and UHF antennas. Spacing between antennas is inadequate.



**Fig. 9** The lead-in and standoffs employed in this TV antenna system are inadequate for the application.

pick up the unwanted signal, or its resolution may be inadequate to display it. Remember that a good visual inspection of the antenna is often the most effective technique.

If ringing or edge-effect originate in the receiver, in all likelihood shop maintenance will be required. Generally, but not always, edge-effect originates in the video amplifiers, and ringing is the result of misalignment. The square-wave-testing techniques described in past issues of **ELECTRONIC SERVICING** will help to determine the source of trouble.

One other problem, flashing, can be caused by faults in either the

receiver or the antenna. If it is caused in the receiver, an intermittently shorted tube or transistor, dirty tuner, loose component, or similar troubles are possibilities. Gently tap the various components until the trouble is located. It is good practice, however, to substitute the tuner tubes first because the tapping may change the intermittent short into a permanent one, seriously damaging other components.

#### **Causes Of Antenna Problems**

The following series of photographs illustrates rather effectively how an

antenna should not be installed. All these pictures were taken of one installation and, needless to say, the UHF reception is very poor. The station, Channel 19, is about 50 miles from the receiving antenna, and fair reception is possible with a properly installed antenna system. The UHF antenna and the rotator, Fig. 8, were added to an existing VHF installation.

First, the UHF antenna used was not designed for fringe-area color reception; contrast it with the VHF antenna, which was. Incidentally, it is usually a good practice to space the UHF antenna at least  $\frac{1}{2}$  wavelength away from the VHF an-



**Fig. 10** Eyelet-type standoff shown here acts as a shorted turn around UHF lead-in, causing multiple ghosts and other similar trouble symptoms on the TV screen.



**Fig. 11** Unshielded lead-in and rotator cable are routed side by side along a steel I-beam and across two warm-air heat ducts—examples of poor installation practices.

# How to write a great ad.

Tell people what you will do for them. How you're different. This is most important.

Your services are more important than your name.

Be under the proper headings so people can find you fast. Maybe you should be under both "Heating" and "Plumbing."

**Emergency Service  
Day or Night**

**BARRY'S HEATING & PLUMBING**

Since **BHP** 1921

**COMMERCIAL,  
INSTITUTIONAL, RESIDENTIAL,  
INSTALLATION & REPAIRS**

<p><b>Complete line of:</b></p> <ul style="list-style-type: none"> <li>• Kitchens</li> <li>• Laundries</li> <li>• Sewage Systems</li> <li>• Water Pumps</li> <li>• Heating Systems</li> <li>• Pipes and Drains</li> </ul>	<ul style="list-style-type: none"> <li>★ Master Lic. #103241</li> <li>★ References</li> <li>★ Estimates</li> <li>★ Delayed Payment Plans</li> <li>★ Ample Parking</li> </ul>
---	--

phone **555-2368**

**77 Locust Lane. (Between Main and Central, one mile from RR. Station).**

Tell people about your special services...repairs...rentals.

Use your logotype to gain recognition. Give facts about your qualifications, reliability, etc.

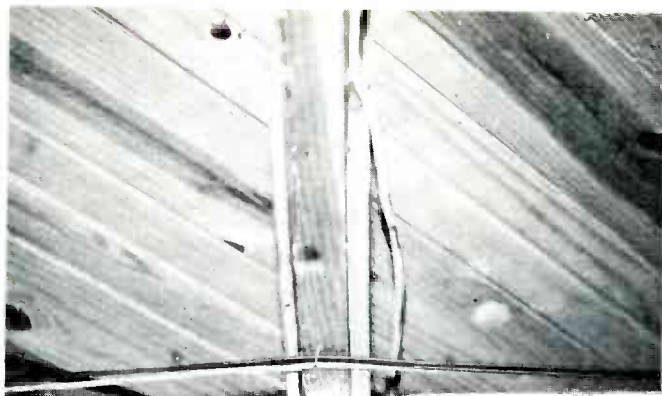
List products you carry.

Tell how easy it is to deal with you...credit, parking, hours, delivery.

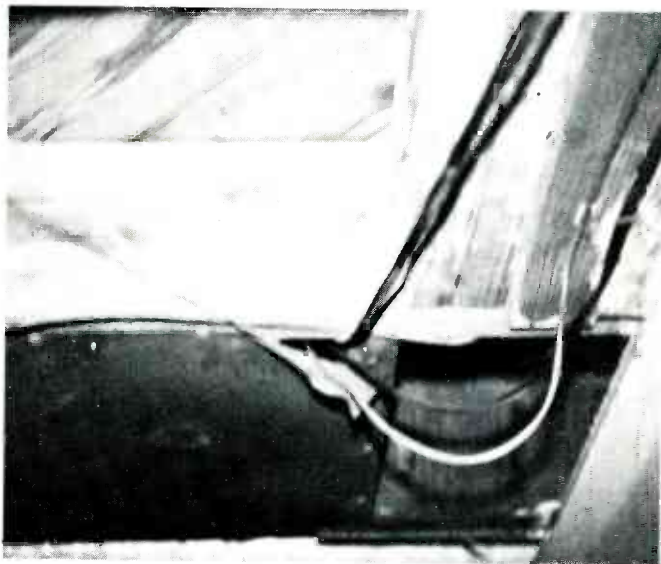
Give telephone number and address, of course; and if you're hard to locate, directions and perhaps a map.

There...you've written a great ad. Now place it where people will be looking for you...in the Yellow Pages.

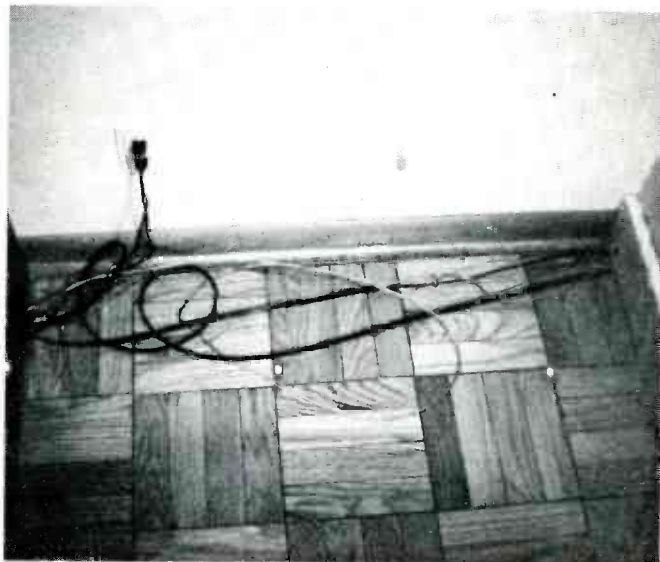




**Fig. 12** Bent nail is used in place of a UHF standoff—another example of poor installation practice.



**Fig. 13** Antenna lead-ins and rotator cable are bundled together and routed inside a metal cold-air-return duct—poor installation practice.



**Fig. 14** "Rats nest" of unshielded antenna lead-in increases attenuation and standing waves—undesirable by-products of poor installation.

tenna at the lowest frequency to be received. Channel 2 was the lowest channel in this case, and the spacing should have been eight feet. However, although the spacing was not proper, Channel-2 reception did not appear to be impaired in this installation.

Fig. 9 shows two other "don'ts": The type of lead-in used for UHF in fringe areas should be the oval or round, foam-filled type. The flat, twin-lead type used here will become covered with dirt, with the results mentioned previously; this dirt also changes the impedance of the line, thereby increasing the standing-wave ratio.

A much more serious cause of high SWR is the type of stand-off used. The eyelet type shown in Figs. 9 and 10 acts much as a shorted turn around the UHF lead-in, causing serious reflections. These are often the cause of the multiple-ghost symptoms mentioned earlier. The effect is less noticeable on VHF, but in strong-signal areas color reception may be impaired by this type of stand-off. UHF stand-offs must be used for UHF; they are preferred for VHF.

The half-loops in the lead-ins at the roof-line (Fig. 9) probably should be tighter to prevent them from flexing in the wind. If a UHF lead is allowed to flex back and forth, toward and away from another conductor, the signal at the receiver may vary excessively, causing a condition similar to that caused by an aircraft flying through the transmission path.

The drip loops shown in Fig. 10 are well formed to prevent water from running down the cables into the basement. Notice, however, that the lead-in and the rotator cable share a single hole through the wall into the basement. This is undesirable because the rotator cable will absorb energy from the lead-in and also increase the SWR.

The use of flat lead-in for UHF inside a building is permissible, since the losses in it are about the same as the losses in foam-filled line, if it is properly installed and kept clean and dry. If flat lead-in is to be used inside, the splice between it and the foam-filled line must be properly made to prevent losses and reflections.





## New Weller® TEMPMATIC®

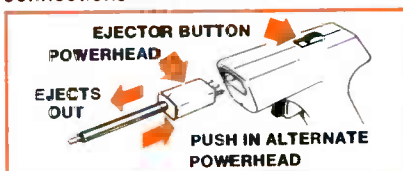
Temperature Controlled Soldering Tool  
for light and heavy duty soldering.

**Now one tool combines all the advantages of a lightweight pencil type iron, a fast heating soldering gun, and tip temperature control.**

### Features Weller's exclusive new POWERHEAD

The heart of this new tool is its long-life, high efficiency POWERHEAD . . . another great innovation from Weller. The POWERHEAD contains Weller's temperature control system (which has been so successful in Weller temperature controlled soldering irons). The result is maximum protection of components even in the most delicate work situations.

The integral points of the POWERHEAD have made over 30,000 solder connections in lab tests.



The points have a special premium plating which vastly extends life. And the POWERHEAD completely eliminates filing and frequent tip changes as encountered with conventional

non-temperature controlled tools.

Two POWERHEADS are available: A 700°F.  $\frac{3}{16}$ " chisel point POWERHEAD or a 600°F.  $\frac{1}{8}$ " conical point POWERHEAD. A convenient ejector button makes switching POWERHEADS easy.

The entire tool weighs only 7 ounces. Its trigger turns heat on and off. And the stainless steel barrel has long reach.

Ideal for service, repairs, PC boards, models and hobbies. Order these new Weller TEMPMATIC models now.

*Weller*®

**WELLER ELECTRIC CORP., Easton, Pa.** World leader in soldering tools

Circle 16 on literature card

Figs. 11, 12 and 13 illustrate some other deficiencies in this installation. The UHF lead-in and the rotator cable are routed side-by-

side, and both are within an inch or so of a steel I-beam for a distance of about 15 feet. Fig. 11 shows how the lead-in lies against

two warm-air heating ducts. Fig. 12 shows a bent nail used instead of a UHF stand-off. Fig. 13 shows the UHF and VHF lead-ins bundled with the rotator cable and all three laid inside a metal cold-air-return duct.

Finally, the familiar "rats nest" is shown in Fig. 14. Not only does this mess alienate housewives, it also increases standing waves and attenuation. A much better method of bringing the lead-ins to the receiver is to route them into the partition wall behind the receiver by drilling a hole up from the basement. Then they should be terminated to a wall plate mounted on the wall. Short lengths of lead-in from the wall plate to the receiver complete the job; the receiver can be moved for service by unplugging the leads from the wall plate. A metal switch box should not be used behind the wall plate because of its effect on UHF.

No splices were used here, but splices in lead-in are a constant source of reception problems. Improperly made, a splice can become shorted, completely cutting off the antenna signal. More frequently it becomes wet, causing attenuation; or it presents an impedance mismatch, causing standing waves. Properly made, a splice is completely satisfactory; however, numerous splices should be avoided, especially when exposed to the elements, because of the possibility that they will become wet or mechanically separated.

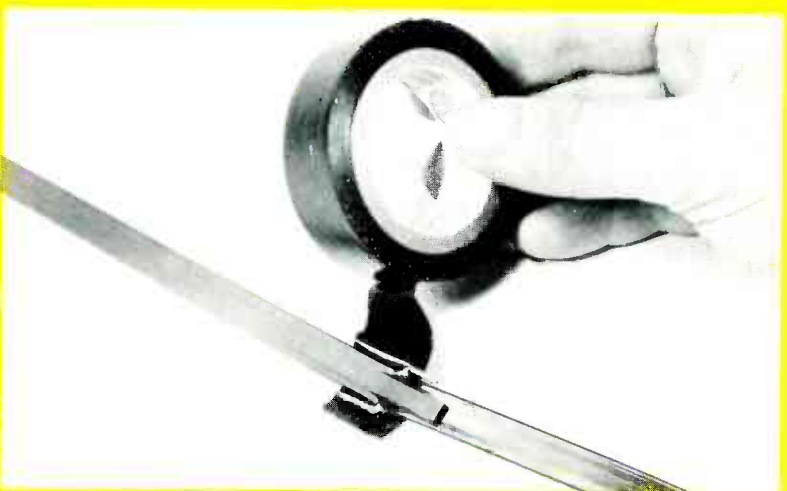
Proper splicing techniques are illustrated in Figs. 15 and 16. As shown, the conductors should be stripped out of the web of the flat line for about 1 inch (the insulating material is not cut). The ends are lapped together; then the conductors are twisted together, soldered, and bent parallel to the line (excess conductor should be cut off). Finally, the splice should be covered with a good grade of plastic tape. Stand-offs should be installed on each side of the splice to protect it from strain and flexing.



(A) Cut and form plastic tabs



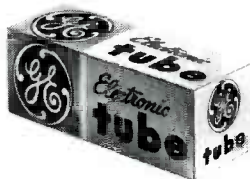
(B) Overlap tabs and twist wires



(C) Tape joint

Fig. 15 Method of splicing flat twin lead.

# GE redesigns tubes to satisfy these tough customers before you get them!

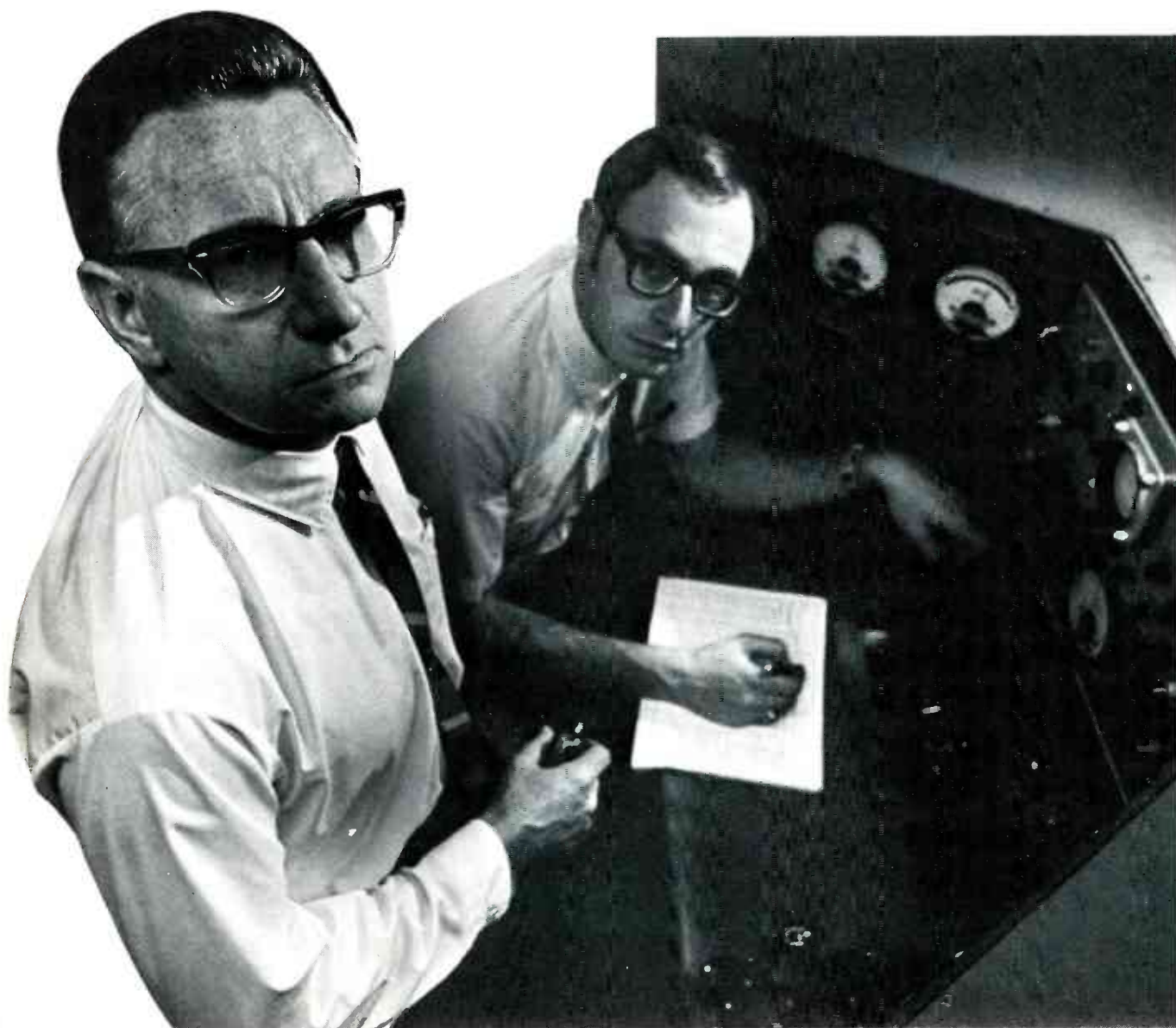


Reach for this when you ask,  
"What else needs fixing?"

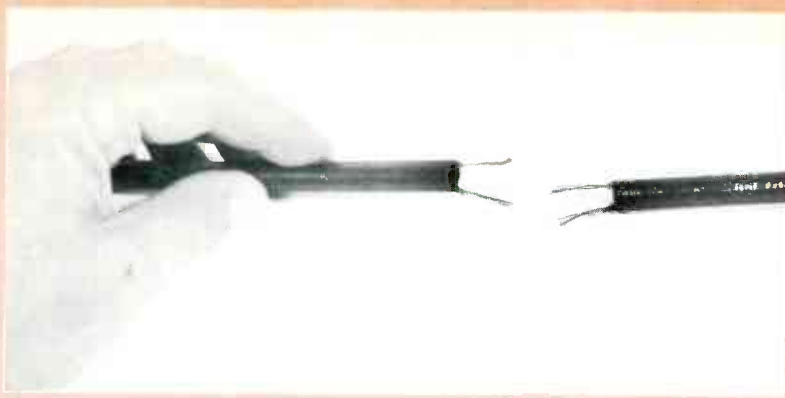
Tube designers at General Electric work for a real *tough customer*. He's our design chief Chris McCool — a stickler for longer life and greater reliability in tubes for replacement use. If a production type can be made better, he'll see to it. His GE designers found a way to dissipate plate heat for less operating fatigue . . . resulting in longer life. They pioneered an improved cathode coating that resists flaking which used to cause shorts. Microphonics in horizontal output tubes were eliminated in another design. These are just a few examples of tubes redesigned by GE for your replacement needs. They're part of the "service designed" line — dependable tubes you can stake your reputation on. Stock up now at your GE distributor.

288-25

GENERAL  ELECTRIC







(A) Cut ends and strip wires.



(B) Insert supporting rod.



(C) Twist wires securely.



(D) Tape joint with good-quality electrical tape.

Fig. 16 Method used for splicing tubular twin-lead.

### Summary

Although reception problems sometimes may be difficult to isolate, a knowledge of how various deficiencies in the entire receiving system affect reception will often provide a key to the solution. A weak picture (one lacking contrast) with little or no snow is normally a fault of the receiver. Excessive snow may be caused by either antenna or receiver, since the AGC system will cause the receiver to amplify whatever signal is available, whether signal or noise, to the design level. Excessive gain, wherein overloading of the receiver is the most prominent symptom, is usually an AGC fault. Finally, distortion of video and loss of color may be caused at nearly any point from the antenna to the CRT. By using a small portable receiver, most reception problems may be quickly isolated to either the antenna or the set.

In many instances, a visual inspection of the antenna system will show the cause of trouble. Obvious faults are broken antennas and lead-ins and gross installation defects such as misoriented antennas, lead-in wrapped around the mast, etc. More subtle faults are improper stand-offs, wet splices, corroded connections, shorted lightning arrestors, coiled unshielded lead-in, and unshielded lead-ins routed with rotator cable. In many cases, poor reception is the result of an accumulation of several minor faults, no one of which seems to have much effect on performance. For example, an antenna which happens to produce a moderate standing-wave ratio on a certain channel may cause no problem by itself. But aggravate this with a bad splice, or a metal duct against the unshielded lead-in, or a coil of unshielded lead-in behind the receiver, and the picture may be seriously degraded.

It seems almost too obvious to state; but no receiver can improve an improper signal fed to it. So, if in doubt, go over the antenna system carefully before deciding that the receiver is at fault. ▲

Krylon® Crystal Clear is standard equipment for all installation and service work. It prevents many of the causes of picture

fading and high voltage losses and keeps lead-in connections tight. It's the repairman's handiest repairman.



Borden Chemical, Division of Borden Inc



# radio-tv repairman

Circle 17 on literature card

# Color TV Setup . . . The Professional

## Part 2 of a 2-Part Series:

### Purity

### Black-and-white tracking Convergence

by Wayne Lemons

Last month we discussed the preliminary adjustments for color sets. As was pointed out in Part 1, don't perform a complete color setup procedure if a preliminary check shows it isn't necessary. If the set makes a good picture at normal viewing distance and the customer is satisfied, then you only borrow trouble by pointing out small discrepancies and attempting to remove them. This does not mean that you shouldn't make sure that the set is adjusted as well as is possible, it just means that there is a point at which additional adjustments produce minimal, unnoticeable and unappreciated returns.

In this installment we will discuss proven techniques for obtaining satisfactory purity, black-and-white tracking and convergence plus a brief review of other color adjustments. As in the first installment of this two-part series, each category will be discussed in the sequence in which the overall color setup should be performed.

### Purity

Don't start a complete purity adjustment unless you have first checked to see if it is necessary. Turn on the set; allow it to warm up 10 minutes or so, then use a portable degaussing coil to make sure demagnetization of the picture tube and chassis is complete. Next, check the purity in the following manner:

1. Connect the RF output of a crosshatch generator to the antenna terminals of the set. (If the generator has a "patternless" position, you can use this if desired, but crosshatch or dots will work just as well. The primary

consideration is that you have enough signal to produce a noise-free raster. If the set has a RASTER position on the setup switch, you can use this instead of the generator, if you wish.)

2. Turn down the blue and green screen (G2) controls to minimum.
3. Rotate the red screen control to maximum.
4. Set brightness and contrast so there is no blooming.
5. If there are no color spots or splotches on the screen, other than red, the purity is okay.
6. Check the green and blue purity (though they usually will be okay if red is normal) by turning up the associated screen control while turning down the other two.
7. If purity is okay, do a black-and-white tracking procedure as outlined later in this article, and then proceed to the convergence procedure.

If the red raster is not pure, you will have to perform the following complete purity adjustment:

1. Check the position of the components on the neck of the picture tube.
2. Connect the crosshatch generator (set to RF output) to the antenna terminals of the set. Tune in the crosshatch pattern.
3. Check the center convergence and, if necessary, touch it up with the static convergence magnets (red, blue and green and blue lateral). Fig. 1 shows the position of these magnets on two makes of sets; others are similar. In Fig. 2 the technician is adjusting the blue magnet.  
Note: It is extremely important that there is good center convergence or you may not be able to obtain proper purity.
4. Loosen the wing nuts, screws, or clamps holding the deflection yoke and pull it back (without rotating it) until it touches the convergence yoke.
5. If the receiver has centering con-

trols, be sure that the crosshatch pattern is centered on the screen vertically and horizontally.

6. Rotate the blue and green screen controls to minimum.
7. Rotate the purity ring magnets, by spreading the tabs apart until you have the purest red raster in the **center** of the screen. (Don't be concerned with colors at any other area of the screen except the center). **Note: Purity** at the center is obtained with the purity rings. Purity at the outer edges of the screen is determined by the position of the deflection yoke.
8. Carefully push the deflection yoke forward until the **entire** raster is pure red. (If purity is not complete, obtain the best purity possible, then touch up with the purity rings and, again, adjust the deflection yoke slightly, if needed.)
9. Using the crosshatch pattern, check to see that the raster is not tilted. Tighten the yoke-holding devices firmly, making sure the raster does not tilt; if it does, purity will be lost.

**Hint:** Rectangular CRT's are somewhat susceptible to a change of purity after the set warms up. To minimize these changes in purity, use the following procedure:

1. If the set has been on less than 20 minutes, leave the deflection yoke as far to the rear as possible while still maintaining good purity.
2. If set has been operating normally for 2 hours or more, leave the yoke as far forward as possible while still maintaining good purity.

**Hint:** Purity rings often have two sets of tabs, one set rounded and the other square. Do not mix the sets. For example, do not try to obtain purity with a round tab and a square tab close together.

### Black/White Tracking

Black-and-white, or gray-scale, tracking means getting a good black-



# Way

and-white picture that doesn't change in tint as the brightness or contrast control is varied. With the modern color set, tracking isn't a great problem if you follow the procedure outlined here. (If you can't get good tracking using these procedures, there is probably a defect in the circuit that needs correcting—perhaps a resistor changed in value, a leaky capacitor, a defective transistor or tube, or even a defective CRT.)

Following are two different tracking procedures, one for sets with a setup switch and one for sets without. (You can use the procedure for sets without a setup switch to set up those sets with one, if you like.)

Before starting a tracking procedure, check to see that the TINT control (if used) is set to the center of its range. The TINT control (there are other names for this control, such as CHROMIX) should not be confused with the HUE control. The TINT control varies the background screen colors so the customer can get either a brownish or bluish picture to suit his preference.

Turn down the COLOR control so that there will be no possible color interference during setup.

### Procedure For Sets With a Set-up Switch

1. Turn the set to an unused channel (a UHF channel is often best since, in most cases, there will be less noise).
2. Turn the TINT control (if used) to center of its range.
3. Turn the G1 (drive) controls fully clockwise (maximum).
4. Turn all screen controls counterclockwise (minimum).
5. Position setup switch to SET-UP.
6. If new set, turn up red screen control until line blooms or fuzzes. This will eliminate any static charges that might cause settings to vary. Then turn down red screen control until the red line is just barely visible.

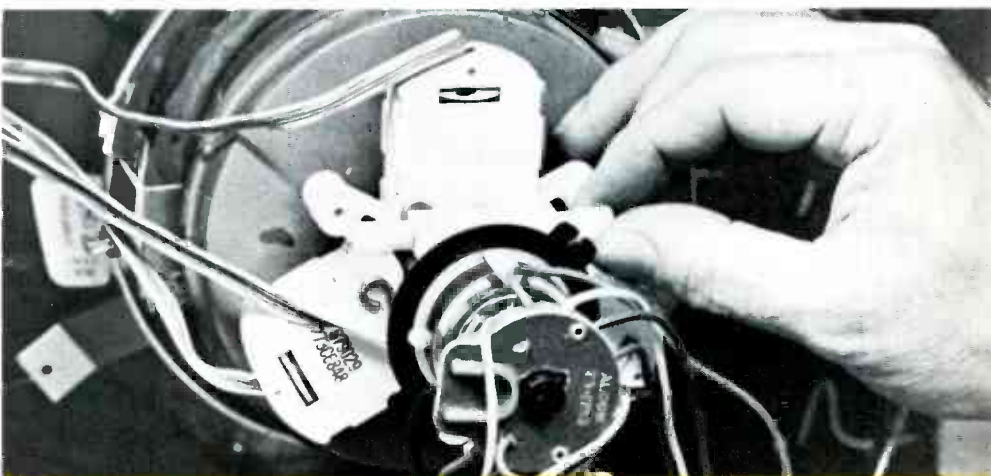
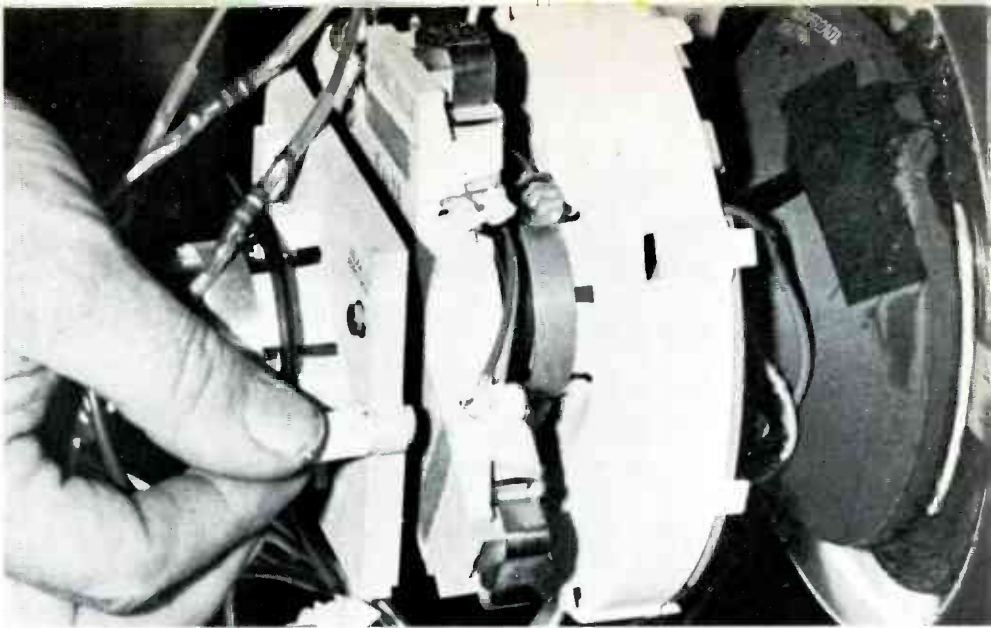


Fig. 1 Convergence assemblies and position of blue lateral magnet adjustments on two current chassis. (Top) Motorola, (Bottom) Zenith.

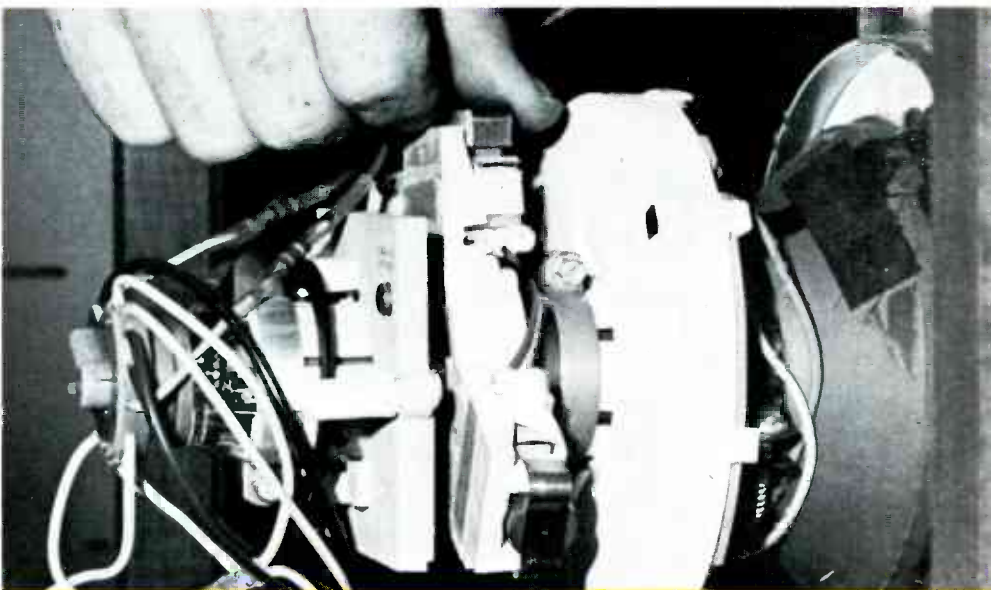


Fig. 2 Technician adjusting blue magnet at top of "cloverleaf" convergence assembly in Motorola color receiver. Blue magnet is used to move the blue beam up and down at the center of the screen.

# now there are **3** time & tool-saving double duty sets

New PS88 all-screwdriver set rounds out Xcelite's popular, compact convertible tool set line. Handy midgets do double duty when slipped into remarkable hollow "piggyback" torque amplifier handle which provides the grip, reach and power of standard drivers. Each set in a slim, trim, see-thru plastic pocket case, also usable as bench stand.



**PS88**

5 slot tip,  
3 Phillips screwdrivers



**PS120**

10 color  
coded nutdrivers



**PS7**

2 slot tip,  
2 Phillips screwdrivers,  
2 nutdrivers

WRITE FOR CATALOG SHEET N563

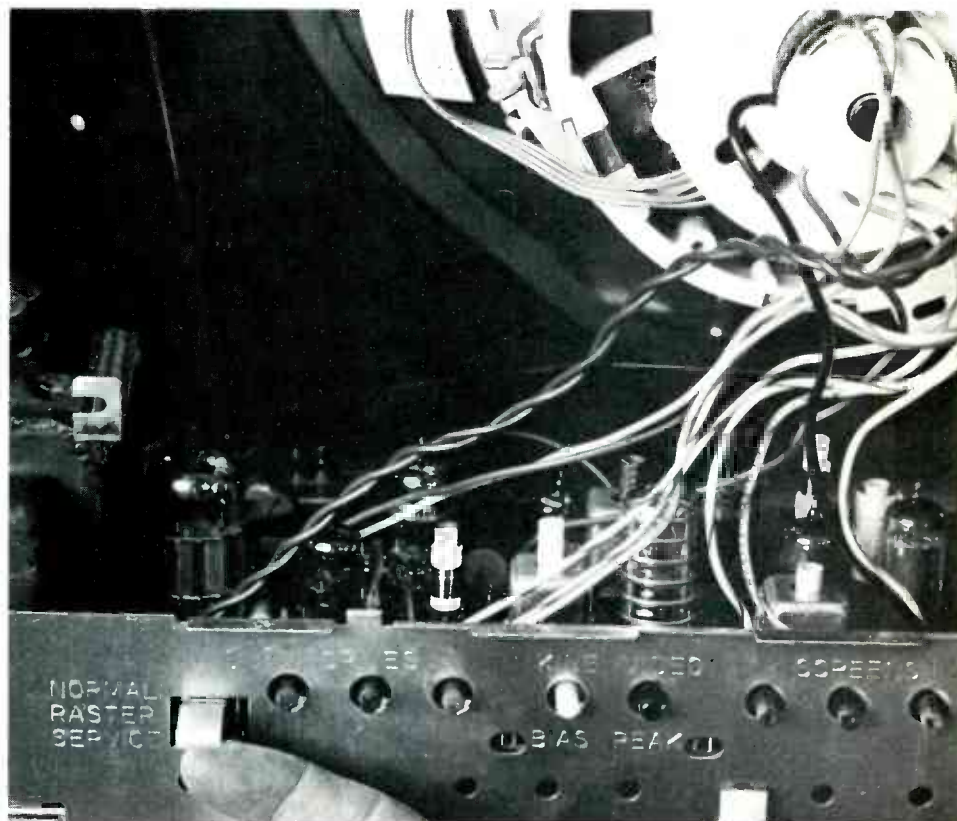


XCELITE, INC., 18 Bank St., Orchard Park, N. Y. 14127  
In Canada contact Charles W. Pointon, Ltd.

Circle 18 on literature card

7. Turn the blue screen up until it is just barely visible (blue line superimposed on the red line).
8. Turn up the green screen control until the horizontal line across the screen appears white (it may be just slightly bluish, if desired).
9. Position the setup switch back to NORMAL (or to RASTER on sets with a raster position, such as that in Fig. 3). The raster now should appear the same as that of a black-and-white set. Any tint in the raster indicates that the gray-scale tracking is incorrect. If tint is evident, reduce the screen control of the predominant color.
10. Tune in a normal picture and adjust contrast and brightness for best picture.
11. Check the highlight areas of the picture, that is, areas of the picture that have the highest brightness level. If a particular color tint predominates in these areas, turn down the drive control for that color. The drive controls are normally set at maximum when the set leaves the factory and usually need to be adjusted only when the color CRT guns change because of aging.
12. Turn the brightness control down. If the raster tends to shift to one color, reduce the screen control associated with that color. Turn the brightness up; if the screen tends to have one predominant color, slightly reduce the associated drive control. When changing to a new picture tube, it may be found that a red tint is predominant; if it is, find the least predominant color and connect the corresponding drive control of that gun to the red gun. For example, if blue is least predominant (weakest saturation), connect the blue grid straight through (as the red was before) and connect the red grid to the blue drive so that the red can be balanced. (The above does not occur often, but often enough that you should be on the lookout for it when you change picture tubes).

**Procedure For Sets Without a Set-up Switch**  
The b-w tracking setup switch



**Fig. 3** Three-position setup switch on an RCA color chassis. The "raster" position provides a snow-free raster for purity or tracking adjustments.



# Join "THE TROUBLESHOOTERS"

who get paid top salaries for keeping today's electronic world running

Suddenly the whole world is going electronic! And behind the microwave towers, push-button phones, computers, mobile radio, television equipment, guided missiles, etc., stand THE TROUBLESHOOTERS—the men urgently needed to inspect, install, and service these modern miracles. They enjoy their work, and get well paid for it. Here's how you can join their privileged ranks—without having to quit your job or go to college to get the necessary training.



JUST THINK how much in demand you would be if you could prevent a TV station from going off the air by repairing a transmitter... keep a whole assembly line moving by fixing automated production controls... prevent a bank, an airline, or your government from making serious mistakes by servicing a computer.

Today, whole industries depend on electronics. When breakdowns or emergencies occur, someone has got to move in, take over, and keep things running. That calls for one of a new breed of technicians—The Troubleshooters.

Because they prevent expensive mistakes or delays, they get top pay—and a title to match. At Xerox and Philco, they're called Technical Representatives. At IBM they're Customer Engineers. In radio or TV, they're the Broadcast Engineers.

What do you need to break into the ranks of The Troubleshooters? You might think you need a college degree, but you don't. What you need is know-how—the kind a good TV service technician has—only lots more.

### Think With Your Head, Not Your Hands

As one of The Troubleshooters, you'll have to be ready to tackle a wide variety of electronic problems. You may not be able to dismantle what you're working on—you must be able to take it apart "in your head." You'll have to know enough electronics to understand the engineering specs, read the wiring diagrams, and calculate how the circuits should test at any given point.

Learning all this can be much simpler than you think. In fact, you can master it without setting foot in a classroom... and without giving up your job!

For over 30 years, the Cleveland Institute of Electronics has specialized in teaching electronics at home. We've developed special techniques that make learning easy, even if you've had trouble studying before. Our AUTO-PROGRAMMED® lessons build your knowledge as easily and solidly as you'd build a brick wall—one brick at a time. And our instruction is personal. Your teacher not only grades your work, he analyzes it to make sure you are thinking correctly. And

he returns it the same day received, while everything is fresh in your mind.

### Always Up-To-Date

To keep up with the latest developments, our courses are constantly being revised. This year CIE students are getting new lessons in Laser Theory and Application, Microminiaturization, Single Sideband Techniques, Pulse Theory and Application, and Boolean Algebra.

In addition, there is complete material on the latest troubleshooting techniques including Tandem System, Localizing through Bracketing, Equal Likelihood and Half-Split Division, and In-circuit Transistor Checking. There are special lessons on servicing two-way mobile radio equipment, a lucrative field in which many of our students have set up their own businesses.

### Your FCC License—or Your Money Back!

Two-way mobile work and many other types of troubleshooting call for a Government FCC License, and our training is designed to get it for you. But even if your work doesn't require a license, it's a good idea to get one. Your FCC License will be accepted anywhere as proof of good electronics training.

And no wonder. The licensing exam is so tough that two out of three non-CIE men who take it fail. But our training is so effective that 9 out of 10 CIE graduates pass. That's why we can offer this famous warranty with confidence: If you complete a license preparation course, you get your FCC License—or your money back.

### Mail Card for 2 Free Books

Want to know more? Mail the bound-in post-paid card for our 44-page catalog describing CIE courses and special book on how to get a Government FCC License. If card is missing, use the coupon below.

### ENROLL UNDER NEW G.I. BILL

All CIE courses are available under the new G.I. Bill. If you served on active duty since January 31, 1955, or are in service now, check box in card or coupon for G.I. Bill information.

**CIE** Cleveland Institute of Electronics  
1776 East 17th Street, Cleveland, Ohio 44114

### Cleveland Institute of Electronics

1776 E. 17th St., Cleveland, Ohio 44114

Please send me without cost or obligation:

1. Your 44-page book "How To Succeed In Electronics" describing the job opportunities in electronics today, and how your courses can prepare me for them.
2. Your book on "How To Get A Commercial FCC License."

Name \_\_\_\_\_ (Please Print)

Address \_\_\_\_\_

City \_\_\_\_\_

State \_\_\_\_\_ Zip \_\_\_\_\_

Occupation \_\_\_\_\_ Age \_\_\_\_\_

Check here for G.I. Bill information  
Accredited Member National Home Study Council  
PF-58

Circle 19 on literature card



# ATR PRODUCTS FOR MODERN LIVING



## ATR UNIVERSAL INVERTERS

A.C. Household Electricity Anywhere . . . in your own car, boat or plane! Operate . . .

- Tape Recorders • TV Sets
- Dictating Machines • Radios
- Public Address Systems • Electric Shavers • Record Players • Food Mixers
- and Emergency Lighting.

NET  
12U-RHG (12 V.) 175-200 W. Sh. Wt. 27 lbs. 79.66  
28U-RHG (28 V.) 150-175 W. Sh. Wt. 27 lbs. 96.66



## ATR "A" Battery ELIMINATOR

For Demonstrating and Testing Auto Radios—TRANSISTOR or VIBRATOR OPERATED!  
Designed for testing D.C. Electrical Apparatus on Regular A.C. Lines.

MAY ALSO BE USED AS A BATTERY CHARGER  
MODEL 610C-ELIF . . . 6 volts at 10 amps. or 12 volts at 6 amps. Shipping weight 22 lbs.

USER NET PRICE . . . . . \$59.82

## ATR AUTO RADIO and COMMUNICATION

### LONGER-LIFE VIBRATORS

"The Best by Test!"



SEE YOUR ELECTRONIC PARTS DISTRIBUTOR OR WRITE FACTORY FOR LITERATURE & DEALER PRICES

## ATR ELECTRONICS, INC.

Quality Products Since 1931

St. Paul, Minnesota 55101—U.S.A.



Circle 20 on literature card

## NEW ENDECO Desoldering Kits

MODEL 300-K KIT SHOWN



All you need to handle almost any desoldering and resoldering job!

Kit 300K includes the famous Endeco pencil desoldering iron Model 300, six different size tips (.038 to .090) for any job, tip cleaning tool, and metal stand for iron . . . all in a handy lifetime steel storage box. \$19.90 net. Model 300K-3 with a 3-wire cord \$20.90. Also a similar kit for military users. Kit 100K with large Endeco iron (Model 100A) is \$27.40, and 3-wire Kit 100AD-3 \$28.40.

SEE YOUR DISTRIBUTOR OR WRITE



## ENTERPRISE DEVELOPMENT CORPORATION

5151 E. 65th St., Indianapolis, Ind. 46220

Circle 21 on literature card

became a standard feature on most sets about 1961. At least one major manufacturer (Motorola), however, does not use a setup switch

in its all-transistor chassis because the composite video and color are mixed together before reaching the picture tube, and a separate video

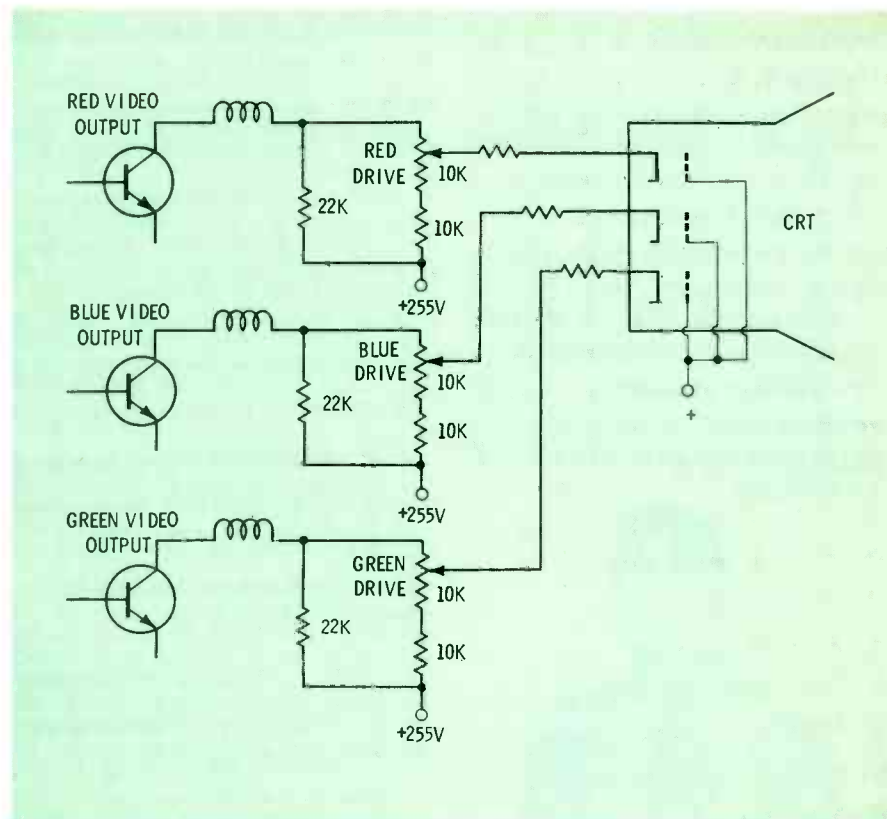


Fig. 4 Color/video driver circuitry employed in Motorola TS915 solid-state color chassis. The CRT control grids are tied together and are not controlled by the chroma circuits; the color signals are matrixed into the video prior to the stages that drive the video output stages shown here.

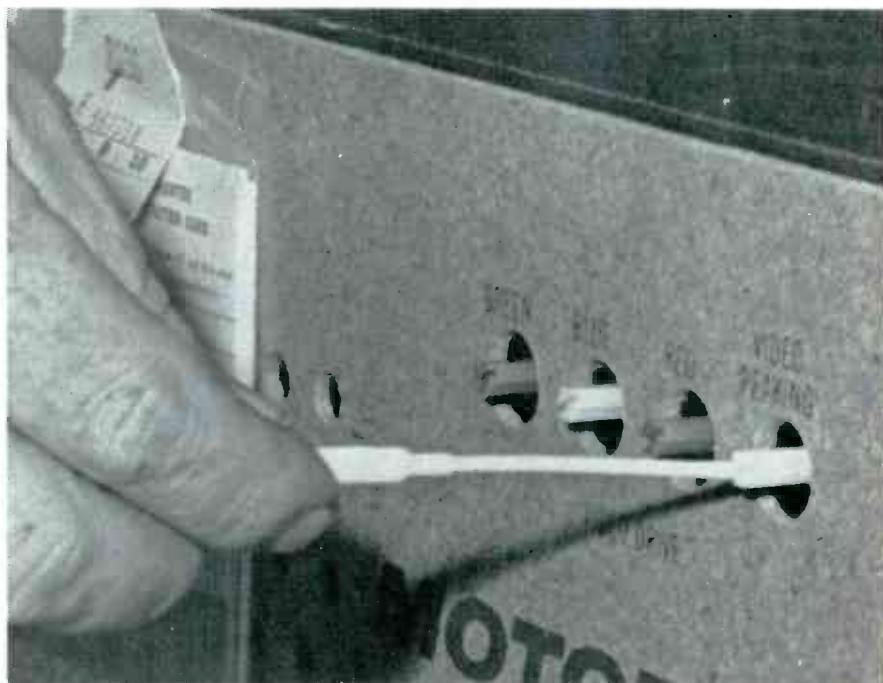


Fig. 5 Adjusting the peaking control in a Motorola chassis. The three drive controls are adjusted during b-w tracking to produce proper balance of the high-brightness areas of the picture.

# NOW CHECK ALL TRANSISTORS IN OR OUT OF CIRCUIT . . .

Flick function switch to left to check all regular transistors.

Flick function switch to right to check any FET.

amplifier is used for each cathode of the picture tube. With three amplifiers it would be awkward, if not impractical, to "fix-bias" each one (as would be necessary) to establish a proper setup bias level. Instead, separate drive controls are used at the output of each video/color amplifier, Figs. 4 and 5. Screen (G2) controls are used on each gun of the CRT the same as on other chassis designs.

To obtain proper b-w tracking of the Motorola chassis, adjust the G2 controls so that the raster is black and white with no color tint at low brightness levels. The video drive controls are then adjusted for no color tint (good black and white) at high brightness levels.

The G2 controls on the gun with the lowest brightness should be set at near maximum. (In some cases, because of the cutoff characteristics of the CRT, adjusting the G2's to maximum will affect the contrast. Reduce the G2's to the point where good contrast is obtained.)

Be sure to check the range of the brightness control and adjust the brightness limiter or range control so that the customer brightness control cannot be turned up to the point where the picture blooms (starts to defocus) or pulls in from the sides.

Following is the step-by-step b-w tracking procedure for such chassis:

1. All drive controls to maximum.
2. Tune in a black-and-white picture. If contrast is not sufficient, be sure to check the AGC adjustment (or you may need to back off the G2's, as suggested previously).
3. Set the Tint control to mid-range. (Again, do not confuse the Tint and Hue controls).
4. Set the contrast and brightness controls to minimum.
5. If there is still a raster and it has a greenish tint (for example), turn down the green G2 control until the raster is black and white. Or, if it changes to a reddish tint, then back off the red G2 control, etc. The idea is to get a very dim black-and-white raster with the brightness and contrast turned down all the way.
6. If you do not obtain a raster with the contrast and brightness at minimum, turn up the brightness until you do. Reduce the



**all regular transistors plus the new field effect transistors.**

You won't be stopped when you run into the new FETs that are wired into the latest hi-fi, newest TV receivers and nearly every other new device coming on the market. For the very first time, you can check them all, in or out of circuit. The TF151 works every time using tried and proven signal injection techniques. New, improved tests on special RF transistors and the latest high power transistors, mean that the TF151 is the only up-to-date transistor tester on the market. A new, exclusive setup book in rear compartment guides you to every test for over 12,000 transistors and FETs. The book is not needed for general service troubleshooting. Regular transistors are checked for beta gain and  $I_{cbo}$  leakage. FETs are checked for transconductance and  $I_{gss}$  leakage. **only \$129<sup>50</sup>**

Your distributor just got this new tester in stock.  
See him, it obsoletes all others.



## SENCORE

NO. 1 MANUFACTURER OF ELECTRONIC MAINTENANCE EQUIPMENT  
426 SOUTH WESTGATE DRIVE, ADDISON, ILLINOIS 60101

Circle 22 on literature card



G2's of the predominant two colors so that they cannot be seen. This leaves the least predominant color. Again turn down the brightness all the way and increase the G2 of the least predominant color until you can see a dim raster of that color. Then, increase the other two G2's until you have a black-and-white raster.

7. Increase the brightness and contrast controls to maximum.
8. Reduce the drive control that corresponds to the most predominant color.
9. Reduce the drive control of the next predominant color until you have a black-and-white picture. (The drive control of the least predominant color should be left at maximum.)
10. Reduce the contrast and brightness to minimum and recheck steps 5 or 6, as needed. Again check steps 7 to 9, etc., until the raster color does not change as the brightness is adjusted from minimum to maximum.

This is good black-and-white tracking: No change in raster tint at any reasonable setting of the brightness or contrast controls.

### Convergence

Convergence, a term that struck fear in the hearts of technicians and even held up color TV sales for many years, is a paper tiger now, if it ever was anything else. Circuit refinements, improved components, improved CRT's and, finally, technician familiarity dissolved all the old anxieties.

There are about three or four "secrets" to successful convergence. The first, and maybe foremost, is "resonance." Instruction books usually say "merge" or "converge" certain lines by turning a certain control or magnet. This is exactly what needs to be done, but there has not been much said about **how** it should be done.

"Resonance", as applied to convergence, means that you move the controls, magnets, or slugs **BACK** and **FORTH THROUGH** the

proper adjustment and then **CENTER**, or "**ZERO IN**", the exact adjustment. It is very similar to aligning a tuned circuit to resonance with a scope or output meter by adjusting a control back and forth and through each side of the peak and finally zeroing in on the exact peak.

Using the "resonance" method, you actually can DC converge a color set on a station picture. Try it and see. Tune in a good picture (color turned down) grasp any one of the static convergence magnets and move it far enough to see the associated color move out around the edges of lines in the picture, then move it in the opposite direction until the color "protrudes" in the other direction. Now move the magnet back and forth while watching the color go through convergence (resonance). You'll see how easy it is to "zero-in" so there is no color fringing at all—and that's convergence.

The second secret is to pay no attention to **slight** imperfections in convergence, especially at the outer

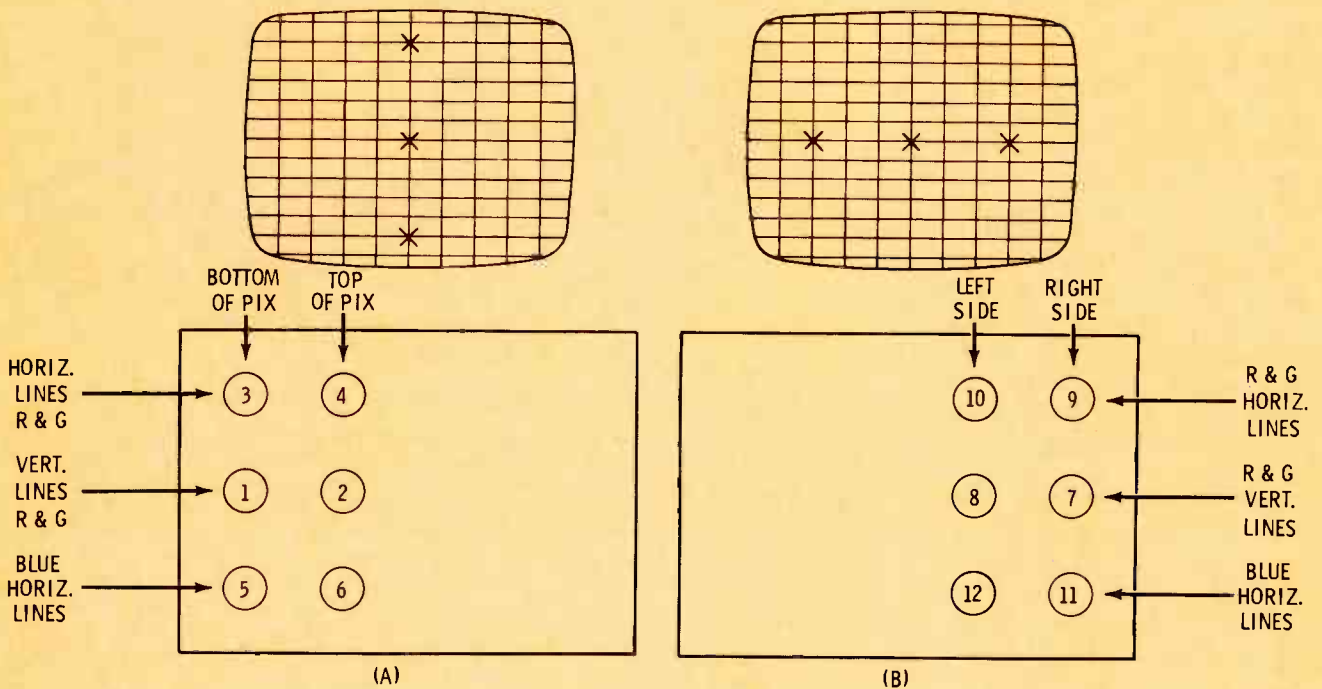


Fig. 6 Controls found on a typical dynamic convergence board. Controls should be adjusted in the sequence indicated while watching the corresponding area of the screen. Repeat center convergence after steps 6 and 12. (A) Vertical (B) Horizontal.



edges of the CRT. (In the quality control department of one of the larger TV manufacturers, a special faceplate cover masks off the outer 1½ inches of the screen while a quality control check of convergence is made.) You should not expect to do much better than the factory technicians. Of two sets of the same model and run, one probably will converge just slightly better than the other, but the only way you or a customer can tell the difference is to see the sets side by side. Even then the difference is not noticeable at normal viewing distances. So don't feel that you are "cheating" the customer if you don't point out the edge discrepancies; they're in nearly every set, and not even the most discriminating viewers will be upset by it unless someone points them out.

The primary consideration is to get the best possible center area convergence out to about two inches from the edge of large screen TV's. Do this and you've done a proper job.

The third secret is to know what each convergence control is supposed to do, and use it for that purpose. If the control says R/G TOP HORIZONTAL, then only pay attention to the red and green horizontal lines at the top of the screen. This control may also have a little effect on the bottom, or even on vertical lines, but pay that no mind. Use the control for its intended purpose. Fig. 6 shows the controls found on a typical dynamic-convergence control board, and indicates the sequence in which they should be adjusted as well as pointing out the areas of the screen that should be watched while performing horizontal and vertical dynamic convergence.

The fourth secret: If only adjustments are needed, you don't need to follow a rigid order or sequence of dynamic adjustments. However, if considerable adjustment is needed, you usually can speed up the procedure by following the manufacturer's suggested sequence. The professional, though, develops a sort of "sixth sense" that comes from experience, and so, under certain circumstances, he can deviate from a fixed sequence.

And that brings us to the fifth secret to successful convergence—DO IT! ▲

# SAMS BOOKS for every electronics interest

## NEWLY PUBLISHED AND IMPORTANT

### Fundamentals of Digital Computers

This exceptionally clear book is an excellent introductory text to the general field of electronic computing. It enables anyone, from any occupational field, to acquire a good, basic understanding of what computers do and how they do it. No prior knowledge of computers is required. The book begins with a discussion of various types of computer applications and surveys the history and evolution of computers. This is followed by an explanation of the fundamental facts one must know and understand about computers and their operation. Discussed in detail are subjects such as the functional organization of a computer, the individual components of a computer system, data preparation, storage devices, input and output peripheral devices, conversion units, and the central processor. A comprehensive glossary of computer terms is included.  
Order 20714, only.....\$5.50

### CB Radio Servicing Guide, 2nd Ed.

Provides a comprehensive guide to CB radio servicing, both for the professional service technician and the CB radio user who wishes to get optimum performance from his equipment. A major part of the book is devoted to troubleshooting procedures aimed at rapid solutions to problems in single-channel and multi-channel receivers and transmitters. Illustrated with CB radio schematics, test equipment diagrams, and charts showing how much range you can expect from CB radio. Includes valuable chapters on field and shop maintenance and the business aspects of CB radio servicing. Order 20722, only.....\$3.95

### FM—From Antenna to Audio

Concise written in clear language, this book presents a complete picture of fm reception and receiving equipment, from the basic principles of fm to the latest developments in afc and tuning aids. The opening chapters thoroughly explain the fm signal and how it is effective in reducing co-channel and adjacent-channel interference. The remaining chapters describe the receiving system, beginning with the fm antenna, and progressing step-by-step through each section of the fm receiver. The two final chapters deal with receiver measurements and alignment procedures.  
Order 20723, only.....\$3.95

## RECENT AND TIMELY BESTSELLERS

### Outboard Motor Service Manuals, 4th Ed.

Complete and accurate service data for the repair and maintenance of outboard motors. Each volume contains a section on outboard motor fundamentals.

Vol. 1. Covers motors under 30 horsepower, produced by 36 leading manufacturers.  
Order 20598, only.....\$4.95

Vol. 2. Full data for motors of 30 horsepower and over, produced by 21 different manufacturers.  
Order 20599, only.....\$4.95  
2 Vol. Set. Order 20603, only.....\$9.50

### Color-TV Servicing Guide

Shows how to apply fast troubleshooting procedures, based on analysis of trouble symptoms. Includes full-color picture tube photos showing various operating troubles; clearly explains how to diagnose trouble causes; gives repair procedures. Order 20358, only.....\$4.25

### Television Service Training Manual, 2nd Ed.

Updated and expanded to include new TV servicing short cuts and tests. Shows how to use test points to isolate trouble to specific components, in both tube and transistor receivers. Treats all sections of the TV receiver; packed with schematics, charts, and drawings. Provides you with quick, sure-fire analysis and repair procedures. Order 20628, only.....\$4.95

### Know Your VOM-VTVM, 2nd Ed.

This authoritative text explains volt-ohm-milliammeters, vacuum-tube-voltmeters, and solid-state electronic voltmeters in language anyone can understand. Includes clear explanations of the types of circuits used, and of the uses, care, and repair of the instruments. Basic concepts are thoroughly presented to help provide for an understanding of electrical measurements. Questions at the end of each chapter help to reinforce learning progress.  
Order 20676, only.....\$3.50

### AM-FM-TV Alignment

Here is all you need to know about alignment of all radio and tv sets. Includes chapter on audio amplifier frequency-response checks.  
Order 20602, only.....\$3.95

### Troubleshooting with the Oscilloscope.

Shows practical use of the scope to isolate circuit troubles. Tells how to setup for tests, how to use probes, how to interpret waveforms, how to troubleshoot. Order 20550, only.....\$4.50

### Practical Transistor Servicing, 2nd Ed.

Provides fastest, most direct methods for troubleshooting all types of transistorized equipment, including FM and auto radios.  
Order 20314, only.....\$4.25

### NEW 5TH EDITION OF THE WORLD-FAMOUS Reference Data for Radio Engineers

Now contains 50% more data to cover the developments of the past 12 years. Prepared by outstanding engineers, professors, and experts, under the direction of the International Telephone and Telegraph Corporation staff. Provides comprehensive data on all basic phases of electronics, including tables, formulas, standards, and circuit information—PLUS—all-new data on micro-miniature electronics, navigation aids, reliability and life testing, international telecommunication recommendations, switching networks and traffic concepts, and quantum electronics. Over 1350 illustrations 1198 pages. Order 20678, only.....\$20.00

### More Bestselling Sams Titles

- Tube Substitution Handbook, 12th Ed.  
Order 20700, Shop Edition, only.....\$1.75
- Troubleshooting with the VOM and VTVM  
Order 20481, only.....\$3.95
- Transistor Substitution Handbook, 9th Ed.  
Order 20705, only.....\$1.95
- Using Scopes in Color-TV  
Order 20718, only.....\$3.95
- Symfact® Guide to Color-TV Servicing  
Order 20710, only.....\$3.95
- Transistor Color-TV Servicing Guide  
Order 20693, only.....\$4.50
- Using Scopes in Transistor Circuits  
Order 20662, only.....\$4.50

## HOWARD W. SAMS & CO., INC.

Order from any Electronic Parts Distributor, or mail to Howard W. Sams & Co., Inc., Dept. ES-6 4300 W. 62nd St., Indianapolis, Ind. 46268

Send books checked at right, \$\_\_\_\_\_ enclosed.

Send FREE 1969 Sams Book Catalog

Name \_\_\_\_\_

PLEASE PRINT

Address \_\_\_\_\_

City \_\_\_\_\_ State \_\_\_\_\_ Zip \_\_\_\_\_

- 20714  20602
- 20722  20550
- 20723  20314
- 20598  20700
- 20599  20481
- 20603  20705
- 20358  20718
- 20628  20710
- 20678  20693
- 20676  20662

Circle 23 on literature card

# test equipment report

## Digital Measuring System

The comparatively small levels of DC voltage employed in nearly all types of solid-state circuits, and the related fact that defects in solid-state circuits usually cause only minute DC voltage variations, have created the need for measuring systems that provide accurate and easy-to-read indications of relatively small quantities, such as millivolts and milliamps.



Hickok Electrical Instrument Co. has developed a measuring system that meets these requirements and, in addition, permits measurement of a variety of electronic quantities and parameters.

The Hickok Model DMS 3200 Digital Measuring System consists of a "main frame" read-out and power unit into which can be plugged any one of nine plug-in measuring units and an adapter, providing measurement of DC voltage from 1 microvolt to 999.9 volts, AC voltage from 10 microvolts to 999 volts, resistance from 1 milliohm to 999 megohms, capacitance from .001 picofarad to 9.99 millifarads, DC current from .0001 microamps to 9.99 amps, frequency from .1 Hz to 100MHz, time interval from 10 microseconds to 999 seconds, and events up to 1,000,000 per second. All units, including the main frame, are completely solid-state.

Two main-frame models are available, DMS 3200A and DMS 3200P. The performance of both is similar, except that Model DMS 3200P has a buffer-storage circuit that permits selection of a non-blinking display; it also has a 10-line decimal data output circuit that can be used to operate an external digital printer.

The main-frame unit contains a three-digit Nixie tube display system and a power supply that furnishes operating voltages for both the main-frame circuitry and the plug-in units.

The circuitry of the main-frame unit is all solid-state, most of which is contained in integrated circuits. Other features of the main-frame unit include a wrong-polarity warning indicator; polarity indicator; a recessed, glare-resistant, see-through shield over the display sector; decimal indication; 5-MHz response of counter circuitry; and both sides of the input power line are equipped with a switch and a fuse.

The main-frame unit is 9 $\frac{5}{8}$  inches wide by 6 $\frac{7}{8}$  inches high by 12 $\frac{7}{8}$  inches deep, including handles and feet. The unit weighs 10 lbs. The price of Model DMS 3200A is \$375.00, and the Model DMS 3200P is priced at \$450.00.

General specifications and prices of the plug-in units are:

### DC Voltmeter Plug-In (DP 100)

- Range: .1 millivolt to 999 volts in five ranges
- Accuracy:  $\pm 0.1\%$  of reading  $\pm 1$  digit
- Input impedance: 10 megohms (on all ranges)
- Variable display time ( $\frac{1}{2}$  to 6 seconds per reading) or can hold reading indefinitely
- Two inputs—direct or probe
- Input protected from overload (1000 volts protection on all ranges)
- All solid-state
- Size: 3 inches high by 8 $\frac{1}{4}$  inches wide by 10 $\frac{1}{8}$  inches deep
- Weight: 3 $\frac{1}{4}$  lbs.
- Price: \$175.00.

### DC Microvoltmeter Plug-In (DP 110)

- Range: 1 microvolt to 999.9 volts in six ranges
- Accuracy:  $\pm 0.05\%$  of reading  $\pm 1$  digit
- Input impedance: 10 megohms (all ranges)
- Input overload protection:  $\pm 1,000$  volts on lowest two ranges,  $\pm 1,500$  volts on all other ranges
- Variable display ( $\frac{1}{2}$  second to 2 $\frac{1}{2}$  seconds) or can hold reading indefinitely
- Two inputs—direct or probe
- All solid-state
- Size: Same as DP 100
- Weight: 4 $\frac{3}{4}$  lbs.
- Price: \$450.00.

### AC Voltmeter Plug-In (DP 130)

- Range: 10 microvolts to 999 volts in six ranges
- Accuracy:  $\pm .1\%$  reading  $\pm 1$  digit at 22Hz-100KHz to  $\pm 2.0\%$  of reading  $\pm 0.5\%$  FS  $\pm 1$  digit at 700 KHz-1MHz (Slightly less below 100 microvolts)
- Input impedance: 1000 megohms shunted by 20 picofarads
- Input overload protection: Up to 1500 volts peak
- Variable display time (8/10 second to 4 seconds per reading) or will hold indefinitely
- All solid-state
- Size: Same as DP100
- Weight: 3 $\frac{1}{4}$  lbs.
- Price: \$375.00.

# The prize you get depends on how many tubes you buy.

Every time you buy 20 Sylvania receiving tubes from your distributor, he gives you a certificate called a "Bright Buck," which works like a trading stamp. When you've collected enough Bright Bucks, you turn them in for prizes.

You can choose any prize, or any number of prizes from the catalog we send you. As long as you've got enough Bright Bucks. Naturally, the

more Bright Bucks you have, the more (or the bigger) prizes you get.

It's a good deal because you can't lose, and there are no chances to take. So when you buy tubes, just make sure they're Sylvania.

It's not exactly getting something for nothing. But it's close.

**SYLVANIA**  
GENERAL TELEPHONE & ELECTRONICS



*Circle 24 on literature card*



**WORLD'S  
FINEST**



**ERSIN  
MULTICORE**

**ONLY 69¢**

**BUY IT AT RADIO-TV PARTS STORES**

Multicore Sales Corp. Westbury, N.Y. 11591  
Circle 25 on literature card

**RMS BEST PERFORMING  
UHF CONVERTERS**



**SOLID-STATE TWO TRANSISTOR  
DELUXE UHF CONVERTER  
HAS BUILT-IN AMPLIFIER!**

Updates any VHF TV Set to receive any of the 83 UHF/VHF Channels. Low noise, drift-free operation. Simple hook-up. Charcoal Gray Hi-Impact Plastic Housing has Silver-matte finish front panel. Features accurately calibrated UHF dial, UHF/VHF antenna switch, advanced pilot light indicator, and tuning control. Model CR-300 List \$34.95

**RMS SOLID-STATE  
ECONOMICAL  
UHF CONVERTER**



Two transistor advanced circuitry. Durable metal housing has wood grain finish and Satin Gold front panel with Black knobs having Gold inserts. #CR-2TW List \$27.95

**RMS UHF ANTENNAS . . .**

Top performers for all areas! Brings clearest Color and Black and White Reception on all UHF Channels 14-83. Features Reynolds Aluminum COLORWELD!

Write for FREE Information on these and other Profit Building Products. . .

**RMS ELECTRONICS, INC.**

TEL. (212) TY 2-6700

50 ANTIN PLACE, BRONX, N. Y. 10462

Circle 26 on literature card

**Ohmmeter Plug-In (DP 170)**

- Range: 1 milliohm to 999 megohms in nine ranges.
- Accuracy:  $\pm 0.1\%$  of reading  $\pm 1$  digit between 0-9.99 ohms to  $\pm .5\%$  of reading  $\pm 1$  digit between 0-999 megohms
- Wheatstone bridge design with automatic null-out and display
- All solid-state
- Size: Same as DP 100
- Weight:  $3\frac{1}{2}$  lbs.
- Price: \$275.00

**DC Current Meter Adapter (D 310)**

- Used with DP 110 Microvoltmeter Plug-In
- Range: .0001 microamps to 9.99 amps in 8 ranges
- Accuracy:  $\pm 0.15\%$  of reading  $\pm 1$  digit
- Automatic polarity reversal and display
- Push-button range expansion
- Input isolation: 10,000 megohms between input ground and chassis or power line ground.
- Size: 1 5/16 inches high by 9 3/8 inches wide by 11 1/2 inches deep (mounts beneath DMS main frame)
- Weight: 3 lbs.
- Price: \$90

**Capacity Meter Plug-In (DP 200)**

- Range: .001 picofarad to 9,999 microfarads in eight ranges
- Accuracy:  $\pm 0.1\%$  of reading  $\pm 1$  digit
- Voltage applied to capacitor under test: 1 volt, millifarad range; 2 volts, all other ranges
- Size: Same as DP 100
- Weight:  $3\frac{1}{2}$  lbs.
- Price: \$275.00

**1MHz Counter Plug-In (DP 150A)**

- Frequency measurements: 00.1Hz to 999KHz
- Period measurements: 00.1 milliseconds to 999 seconds
- Accuracy:  $\pm .0005\%$  of reading  $\pm 1$  digit
- Sensitivity: 10.0 millivolts
- Size: Same as DP100
- Weight:  $3\frac{1}{2}$  lbs.
- Price: \$230.00

**80MHz Counter Plug-In (DP 160)**

- Frequency measurements: 00.1Hz to 80.0MHz
- Accuracy:  $\pm 0.00005\%$  of reading  $\pm 1$  digit
- Sensitivity: 20.0 millivolts
- Size: Same as DP 100
- Weight:  $3\frac{1}{2}$  lbs.
- Price: \$395.00

**Event Counter/Slave Plug-In (DP 140)**

- Counting rate: up to 1,000,000 counts per second
- Size: Same as DP 100
- Weight:  $2\frac{3}{4}$  lbs.
- Price: \$90.00

Circle 57 on literature card

**Diode And Transistor Checker**

Texscan Technical Products announces the Model DT-100 Diode and Transistor Checker, a low-current device designed for the sole purpose of determining very quickly whether or not a transistor or diode is good. Being a low-current device, it is capable of testing RF transistors and low-current diodes without damaging them.

The DT-100 is useful for tests of incoming components, as well as tests of semiconductors after they have been mounted. Because the Model DT-100 tests in-circuit, damage due to desoldering and resoldering of semiconductors is eliminated.



The unit is a "go-no-go" type checker. Diodes are checked by touching the leads to the binding posts on the checker in either direction. If the diode is good, the light on the tester will glow. If the light does not glow, the diode either is open or shorted.

Transistors may be checked by clipping one of the test leads supplied with the DT-100 to the base of the transistor and attaching the other lead to the emitter and then to the collector. If the transistor is good, the lamp will glow on both connections. If the lamp does not light in one or both positions, the transistor is bad. The selling price is \$14.95.

Circle 58 on literature card

**Tube/Transistor Tester**

The new EMC Model 215 tube and transistor tester, manufactured



by Electronic Measurements Corp., performs cathode emission, leakage, inter-element shorts and intermittent tests of over 2,000 tubes currently used. The unit also checks the AC Beta of both high- and low-power PNP and NPN transistors. A two-position slide switch, located on the right front of the instrument below the meter, selects either the tube or the transistor test function.

Tubes that can be tested with this unit include compactrons, magnavols, numistors, novars, octals, loctals, "magic-eye", voltage regulators, 7-pin, 9-pin and 10-pin types. Read-out of performance is on a three-color meter scale. A switching arrangement adapts the unit to test new tube types as they become available.

The Model 215 is housed in a bakelite case with carrying strap and operates either from 110VAC, 60Hz or from batteries. Size is 8½ inches high by 7¼ inches wide by 4 inches deep. Weight is 5 lbs. The unit comes complete with batteries, instructions and a ring-bound tube manual.

Price is: \$27.95, kit form; \$42.95, factory-wired and tested.

Circle 59 on literature card

#### ERRATUM

The price listed for Jerrold Model AIM-718 field-strength meter on page 51 of the March issue is incorrect; the correct price is \$198.50. Also, the input impedance of this instrument is 300 or 75 ohms (plug-in adapter).

# WHO?



Yes, Who  
said the ROHN.  
Twist-On Stand-Off

doesn't work?

Let me cue you in. The truth is that the ROHN Twist-On Stand-Off is the most efficient, easiest and fastest to install stand-off you've ever seen, and out performs anything on the market. How's that grab you?

Skeptical? Well, then, if you are, just fill out the coupon below and mail it in and we'll send you FREE 20 ROHN Twist-On Stand-Offs, just to prove our point. Is it a deal?

**ROHN** Manufacturing Co., P.O. Box 2000, Peoria, Ill. 61601

I want proof that the Twist-On Stand-Off is as great as you say it is, so send me my free 20 stand-offs.

Name \_\_\_\_\_  
Firm \_\_\_\_\_  
Address \_\_\_\_\_ State \_\_\_\_\_ Zip \_\_\_\_\_  
City \_\_\_\_\_

**ROHN** Manufacturing Co.  
Peoria, Ill. • Birmingham, Ala. • Frankfort, Ind.  
Circle 27 on literature card

# Profile of the electronic servicing business

A fact-finding survey of readers was conducted in the January, 1969 issue of *Electronic Servicing*. Responses to this survey have been tabulated and the results used to construct the following statistical profile of that segment of the consumer electronic product servicing business who are readers of *Electronic Servicing*.

Respondents to this survey have painted the following picture of the full-time home-entertainment electronic product servicing business:

## THE FULL-TIME SERVICE TECHNICIAN

Over two-thirds of the full-time technicians who responded to questions relating to the following items indicated that they:

- Are self-employed
- Have been servicing electronic products 10 years or more
- Are paid over \$3.00 per hour (40% receive over \$4.00 per hour)
- Are not on an incentive pay plan
- Have attended either a civilian or military technical school
- Attend manufacturers training programs
- Favor some form of licensing and/or certification of technicians
- Do not belong to an electronic service association

Slightly less than two-thirds of full-time technicians who are not self-employed have been with present employer less than 6 years; 27% have been with present employer for 10 years or more.

## FULL-TIME SHOP OWNERS

97% do servicing themselves  
66% have been in business 10 years or more  
21% have been in business less than 6 years

## THE FULL-TIME SHOP

Over two-thirds of full-time technicians responding to questions relating to the following items said their shop:

- Employs 2 or less full-time bench men
- Employs 2 or less outside men
- Does warranty servicing (28% limit warranty servicing to one brand)
- Does **not** offer service contracts on TV, radio and stereo and communications equipment
- Charges \$8.00 or less for b-w home-service calls (first 30 minutes)
- Charges \$10.00 or less for color home-service calls (first 30 minutes)
- Charges \$12.00 or less per hour for bench labor (53% charge \$9 or less)
- Does **not** offer free service estimates
- Does **not** employ apprentice technicians

Less than 10% of full-time shops receive 75% or more of gross income from service labor sales. The combination of service labor sales and replacement parts sales account for the largest part of the typical shop's gross income, with the remainder coming from retail merchandise sales (57% of full-time shops receive 25% or less of gross income from this source).

The largest part of a typical shop's service labor sales come from servicing b-w and color TV (43% of full-time shops receive 21% to 50% of total service labor from b-w TV; 38% receive 21% to 50% from Color TV).

## RATIO OF FULL-TIME TO PART-TIME SERVICERS

62% of readers responding to this series of questions indicated that servicing consumer electronic products is their full-time occupation; of this group, 68% are self-employed.

	Self Employed and/or Shop Owners	Employees of Service Shops	Total Responses
Full Time	796	368	1164
Part Time	569	133	702
			1866

## EXPERIENCE AS ELECTRONIC TECHNICIAN

73% of full-time technicians responding to this question have been servicing electronic products for 10 years or more. 52% of part-time technicians have 10 years or more of experience. Only 11% of total full-time technicians have less than 5 years experience, while 24% of part-time technicians have been servicers for less than 5 years.

	2 But Less Than 2 Years	5 But Less Than 5 Years	10 But Less Than 10 Years	10 or More Years	Total Responses
Full Time	36	76	163	753	1028
Part Time	63	82	149	320	614
					1642

## YEARS EMPLOYED BY PRESENT EMPLOYER

61% of full-time technicians who said they were not self-employed have been with present employer for less than 6 years. 27% of full-time employees have been with present employer 10 years or more.

	Under 2 Years	3 But Less Than 6 Years	6 But Less Than 10 Years	10 or More Years	Total sponses
Full Time	102	122	45	99	368
Part Time	53	27	19	34	133
					501



### SHOP OWNERS WHO ALSO ARE ACTIVE TECHNICIANS

97% of respondents who own full-time service shops do servicing themselves.

	Do Servicing	Do No Servicing	Total Responses
Full Time	765	31	796
Part Time	548	21	569
			1365

### YEARS AS SHOP OWNER

Of those respondents who are owners of full-time service shops, 66% have been in business 10 years or more and 21% have been in business less than 6 years. 47% of part-time shop owners indicated they have operated their own service business for 10 years or more, while 35% said they operated their own business less than 6 years.

	Under 2	3 But Less Than 6	6 But Less Than 10	10 or More	Total Responses
Full Time	66	100	101	514	781
Part Time	68	121	93	249	531
					1312

### FULL-TIME TECHNICIANS PER SHOP

82% of the owners of full-time service businesses said they employed 2 or less full-time bench men and 83% said they employed 2 or less outside men.

	2 or Less	3 But Less Than 6	6 But Less Than 9	9 or More	Total Responses
Bench Men	636	98	17	23	774
Outside Men	604	70	24	32	730

### HOURLY RATE PAID TECHNICIANS

#### Comparison of Typical Rates Paid Full-Time and Part-Time Technicians:

77% of full-time technicians who responded said they are paid more than \$3.00 per hour, and 40% said they received over \$4.00 per hour. Of the part-time technicians responding, 71% said they receive over \$3.00 per hour and 36% are paid more than \$4.00 per hour.

	\$1.50 to \$2.00	2.01 to 3.00	3.01 to 4.00	4.01 to 5.00	Total Responses
Full Time	46	151	320	346	863
Part Time	56	85	173	178	492
					1355

#### Top Salary Range Paid Full-Time Bench and Outside Men and Trainees:

Of the full-time technicians who responded to this series of questions, 74% said experienced bench men in their shop were paid over \$3.00 per hour, and 30% said bench men were paid over \$4.00 per hour. 64% of full-time technicians indicated that experienced outside men in their shop received over \$3.00 per hour, while 21% said outside men received over \$4.00. 58% of full-time technicians responding

to this series of questions said their shop paid trainees \$2.00 or less per hour.

	\$2 or Less	2.01 to 3.00	3.01 to 4.00	Over 4.00	Total Responses
Experienced Bench Men	44	120	276	189	629
Experienced Outside Men	44	163	258	121	586
Trainees	283	177	27	3	490

### TECHNICIANS ON INCENTIVE PAY PLAN

Of those responding to this series of questions, 17% of full-time technicians and 8% of part-time technicians said bench men in their shop were on an incentive pay plan. 19% of full-time technicians and 7% of part-time technicians responding said outside men employed by their shop were on an incentive pay plan.

	Bench Men		Outside Men	
	Full Time	Part Time	Full Time	Part Time
Yes	130	33	148	30
No	651	372	620	375
Total Responses	781	405	768	405

### SOURCES OF SHOP GROSS INCOME

#### Service Labor

Of those responding to this question, 58% of full-time technicians and 57% of part-time technicians said their shop receives 50% or less of gross income from service labor. Only 9% of full-time technicians and 13% of part-time technicians said their shop receives 75% or more of gross income from service labor.

#### Replacement Parts Sales

Of the full-time technicians responding to this question, 52% said their shop receives from 26% to 50% of total gross income from replacement parts sales, and 38% said their shop receives 25% or less of total gross income from this source. 52% of part-time technicians responding said their shop receives from 26 to 50% of total gross from replacement parts sales, while 33% said their shop receives 25% or less of gross income from this source.

#### Retail Merchandise Sales

57% of full-time technicians responding to this question said their shop receives 25% or less of total gross income from retail merchandise sales, while 19% said their shop receives over 50% of total gross from this source. 83% of part-time technicians responding said their shop receives 25% or less of total gross income from this source.

	Service Labor		Replacement Parts Sales		Retail Sales	
	Full Time	Part Time	Full Time	Part Time	Full Time	Part Time
25% or Less	173	112	370	184	441	316
26% to 50%	384	206	498	289	190	37
51% to 75%	316	167	79	69	107	24
Over 75%	90	70	14	14	40	2
Total Responses	963	555	961	556	778	379

## SOURCES OF SERVICE LABOR INCOME

		None	20% or Less	21 to 50%	51 to 75%	Over 75%	Total Responses
B-W TV	Full Time	54	237	441	198	85	1015
	Part Time	25	92	170	171	149	607
Color TV	Full Time	80	211	380	253	86	1010
	Part Time	99	284	141	48	18	590
Stereo	Full Time	105	823	58	5	6	997
	Part Time	133	401	27	8	6	575
Home Radio	Full Time	106	813	64	6	13	1002
	Part Time	49	420	90	24	13	596
Auto Radio	Full Time	310	585	50	10	12	967
	Part Time	168	366	27	10	5	576
MATV	Full Time	733	138	18	3	4	896
	Part Time	494	38	5	0	1	538
CATV	Full Time	820	45	8	2	5	880
	Part Time	504	26	2	0	2	534
Home Antenna	Full Time	306	545	79	10	6	946
	Part Time	196	322	19	6	5	548
Communications Equipment	Full Time	687	161	31	9	19	907
	Part Time	406	113	10	8	10	547
Industrial Electronics	Full Time	707	141	22	10	19	899
	Part Time	445	67	18	4	9	543
Medical Electronics	Full Time	757	65	12	2	8	844
	Part Time	483	20	4	1	4	512

## SHOPS PERFORMING WARRANTY SERVICING

72% of full-time and 28% of part-time technicians responding to this question said their shop performed warranty servicing. 28% of full-time technicians said their shop limited warranty servicing to one brand.

	None	Exclusively One Brand	More Than One Brand	Total Responses
Full Time	282	280	452	1014
Part Time	413	69	96	578
				1592

## SHOPS OFFERING SERVICE CONTRACTS ON FOLLOWING EQUIPMENT:

### TV

69% of full-time and 87% of part-time technicians responding said their shop does not.

	Yes	No	Total Responses
Full Time	310	684	994
Part Time	72	503	575
			1569

### Radio and Stereo

82% of full-time and 90% of part-time technicians responding said their shop does not.

	Yes	No	Total Responses
Full Time	173	816	989
Part Time	55	517	572
			1561

### Communications Equipment

91% of full-time and 96% of part-time technicians responding said their shop does not.

	Yes	No	Total Responses
Full Time	82	877	959
Part Time	23	530	553
			1512

## HOME CALL RATES (FIRST 30 MINUTES) FOR FOLLOWING CATEGORIES:

### B-W TV

75% of full-time and 89% of part-time technicians answering this question said their shop charges \$8.00 or less.

**PERCENTAGE OF TOTAL SERVICE LABOR INCOME FROM FOLLOWING CATEGORIES:**

**B-W TV**

54% of full-time technicians responding to this question said their shop receives from 21 to 50% of total service labor income from this source. 28% of full-time technicians and 50% of part-time technicians said their shop receives over 50% of total service labor from this source.

**Color TV**

38% of full-time technicians responding to this question said their shop receives between 21% and 50% of total service labor income from color TV. 33% of full-time technicians and 11% of part-time technicians said their shop receives over 50% of total service from this source.

**Stereo**

Only 7% of full-time and 7% of part-time technicians answering this question said their shop receives over 20% of total service labor income from this source.

**Home Radio**

8% of full-time and 21% of part-time technicians responding to this question said their shop received over 20% of total service labor from this source.

**Auto Radio**

7% of full-time and 7% of part-time technicians responding to this question said their shop received over 20% of total service labor income from this source.

	\$8.00 or Less	8.01 to \$10.00	10.01 to \$12.00	Over \$12.00	Total Responses
Full Time	731	150	54	34	969
Part Time	505	47	10	1	563
					1532

**Color TV**

75% of full-time and 87% of part-time technicians responding to this question said their shop charges \$10 or less.

	\$8.00 or Less	8.01 to \$10.00	10.01 to \$12.00	Over \$12.00	Total Responses
Full Time	396	318	125	111	950
Part Time	265	175	48	15	503
					1453

**Color TV Setup**

Of the full-time technicians responding to this question, 52% said their shop charges over \$10.00 and 23% said their shop charges over \$12.00. 66% of part-time technicians answering this question said their shop charges \$10.00 or less per hour and 34% indicated that their shop charges \$8.00 or less.

**Home Antenna Systems**

10% of full-time and 5% of part-time technicians replying to this question said their shop receives over 20% of total service labor income from this source.

**MATV**

82% of full-time and 92% of part-time technicians replying to this question said their shop received **no** service labor income from this source.

**CATV**

93% of full-time and 94% of part-time technicians replying to this question said their shop received **no** service labor income from this source.

**Communications**

76% of full-time and 74% of part-time technicians answering this question said their shop received **no** service labor income from this source.

**Industrial Electronics**

79% of full-time and 82% of part-time technicians replying to this question said their shop received **no** service labor income from this source.

**Medical Electronics**

90% of full-time and 94% of part-time technicians replying to this question said their shop received **no** service labor income from this source.

	\$8.00 or Less	8.01 to \$10.00	10.01 to \$12.00	Over \$12.00	Total Responses
Full Time	185	266	271	212	934
Part Time	160	154	118	42	474
					1408

**Stereo and Other**

64% of full-time and 81% of part-time technicians replying to this question said their shop charges \$8.00 or less.

	\$8.00 or Less	8.01 to \$10.00	10.01 to \$12.00	Over \$12.00	Total Responses
Full Time	565	195	78	42	880
Part Time	375	64	18	5	462
					1342

**AVERAGE HOURLY RATE CHARGED FOR BENCH LABOR**

Of full-time technicians responding to this question, 86% said their shop charges \$12.00 or less per hour and 53% said their shop charges \$9.00 or less. 77% of part-time technicians answering said their shop charges \$9.00 or less.



	\$9.00 or Less	9.01 to \$12.00	12.01 to \$14.00	Over \$14.00	Total Responses
Full Time	514	321	78	59	972
Part Time	406	91	19	8	524
					1496

#### METHOD OF PRICING REPLACEMENT PARTS

58% of full-time and 51% of part-time technicians answering use cost plus 51% or more, 30% of full-time and 26% of part-time technicians use cost plus 76% or more.

	Cost Plus 50% Or Less	Cost Plus 51% To 75%	Cost Plus 76% To 100%	Cost Plus Over 100%	Total Responses
Full Time	403	268	241	54	966
Part Time	288	149	138	17	592
					1558

#### FREE SERVICE ESTIMATES

66% of full-time and 39% of part-time technicians answering this question said their shop does not offer free service estimates.

	Yes	No	Total Responses
Full Time	345	665	1010
Part Time	362	233	595
			1605

#### TRAINING

##### Source of Initial Electronic Training

77% of full-time and 78% of part-time technicians responding to this question **have** attended either a civilian or military technical school.

	No Formal Schooling, Practical Experience Only	Civilian Tech School	Military Tech School	Total Responses
Full Time	185	505	130	820
Part Time	118	353	56	527
				1347

##### Technicians Attending Manufacturers' Training Sessions

87% of full-time and 55% of part-time technicians responding to this question attend manufacturers' training programs.

	Yes	No	Total Responses
Full Time	841	124	965
Part Time	258	213	471
			1436

#### Shops Employing Apprentice Technicians

29% of full-time and 14% of part-time technicians responding to this question said their shop employs apprentice technicians.

	Yes	No	Total Responses
Full Time	293	726	1019
Part Time	79	497	576
			1595

#### LICENSING AND/OR CERTIFICATION OF TECHNICIANS

75% of full-time and 59% of part-time technicians responding to this question favor some form of licensing and/or certification of technicians.

	Government Licensing	Associa- tion Certi- fication	Only Local Regu- lation (City or State)	Do Not Favor Any Form of Regu- lation	Total Responses
Full Time	163	242	289	235	930
Part Time	78	112	115	209	514
			404	444	1444

#### SERVICE ASSOCIATION MEMBERSHIP

28% of full-time and 16% of part-time technicians belong to a service association.

	Yes	No	Total Responses
Full Time	290	736	1026
Part Time	99	509	608
			1634

### More Data For You

- How do your operating costs compare with those of other shops of similar size in your area?
- How does your labor-recovery rate compare with that of the rest of the industry?

We can help you answer these and other questions concerning your shop operations and profitability if you will take the time to provide us with the data requested in the *Cost-of-Doing-Business Survey* on page 50 of this issue.

Help ELECTRONIC SERVICING provide you with more facts about your industry—facts that enable you to make your shop more profitable.



# No More Room at the Top?

There's always room... for improvement! And, because RCA understands this, the SK Series solid-state replacement line is constantly updated to meet your growing needs.

Backed by production excellence and premium specifications, RCA's "Top-of-the-Line" series—transistors, rectifiers, integrated circuits—is precisely engineered, manufactured, and tested for use specifically as replacements.

If you're building a name for yourself in solid-state servicing, your solid-state replacements should be RCA SK "Top-of-the-Line" devices. They are top-quality units—no cast-offs, no factory seconds, no unbranded culls.

The line is comprehensive—39 devices that can do the work of almost 13,000 others. Each unit has electrical characteristics comparable to or better than originally designed-in devices. RCA's SK series can be your answer for any needs from small signal to the newest in silicon audio output applications.

RCA SK Series and the types they replace are cross-referenced in the RCA Solid-State Replacement Guide—SPG-202G. Get your copy at your RCA Distributor. Today.

And, if you want an inexpensive way to extend your integrated circuit skill, try RCA's KD2117 Linear IC Variety Pack... includes 5 integrated circuits:



two KD2114 transistor arrays  
one KD2115 audio amplifier  
two KD2116 transistor arrays  
plus  
instructions for 12 useful  
circuits, schematics,  
parts lists, etc.

RCA | Electronic  
Components | Harrison,  
N. J. 07029



# RCA

Circle 28 on literature card

[www.americanradiohistory.com](http://www.americanradiohistory.com)

# Electronic Servicing

## Formerly PF Reporter

1014 WYANDOTTE STREET

KANSAS CITY, MISSOURI 64105

913 888-4664

servicing consumer electronic products . . .  
The Cost of Doing Business

- Effective Service Income Per Manhour Available
- Total Potential Service Income
- Labor Recovery Rate
- Labor Markup . . .

How do these factors of your business compare with those of other shops of similar size in your geographical area?

We need your help to compile the information that will enable you to compare the efficiency and profitability of your business with that of other service dealers of similar size in your geographical area. The information requested in this survey should be available in your operating records for the calendar year 1968.

Your response will be held in strict confidence. No information relating to an individual service dealer will be disclosed. All information will be processed by a computer and published in ELECTRONIC SERVICING in tabular form.

The tabulated results of this survey will be presented in two forms to those who respond:

- A tabular assessment of the cost of doing business and operating standards of this industry will be published as soon as possible in ELECTRONIC SERVICING
- The information supplied by each respondent to this survey will be compared by the computer with the tabulated information from other dealers of similar size in your geographical area, and the results will be mailed under cover to the respondent.

To permit us to provide you with the results of this survey as soon as possible, please fill in the self-addressed form, detach it from the questions, fold on the line indicated and staple or tape it closed (to keep the information private) and drop in the mail before July 15.

--the Editors



# This little part plays a big role in radio.



This box gives you top revues.

The transistor is no bit player when it comes to radio performance. That's why Delco transistors are manufactured under controlled conditions that assure high reliability. And why they're thoroughly tested before being placed in the familiar blue and black box.

Delco Radio engineers are leaders in auto radio design and transistor technology.

Delco radios are original equipment on over half of the cars on the road.

That United Delco box is your guarantee of genuine OEM

quality replacement parts. And just 12 Delco transistors replace over 7,500 other types.

Doesn't it make good sense to stock the best?

Remember these facts when you re-order. And remember, too, that your United Delco supplier handles the most recognized name in the parts business.

Next time you think little, think big. Think Delco.

DELCO RADIO, Div. of General Motors, Kokomo, Ind.



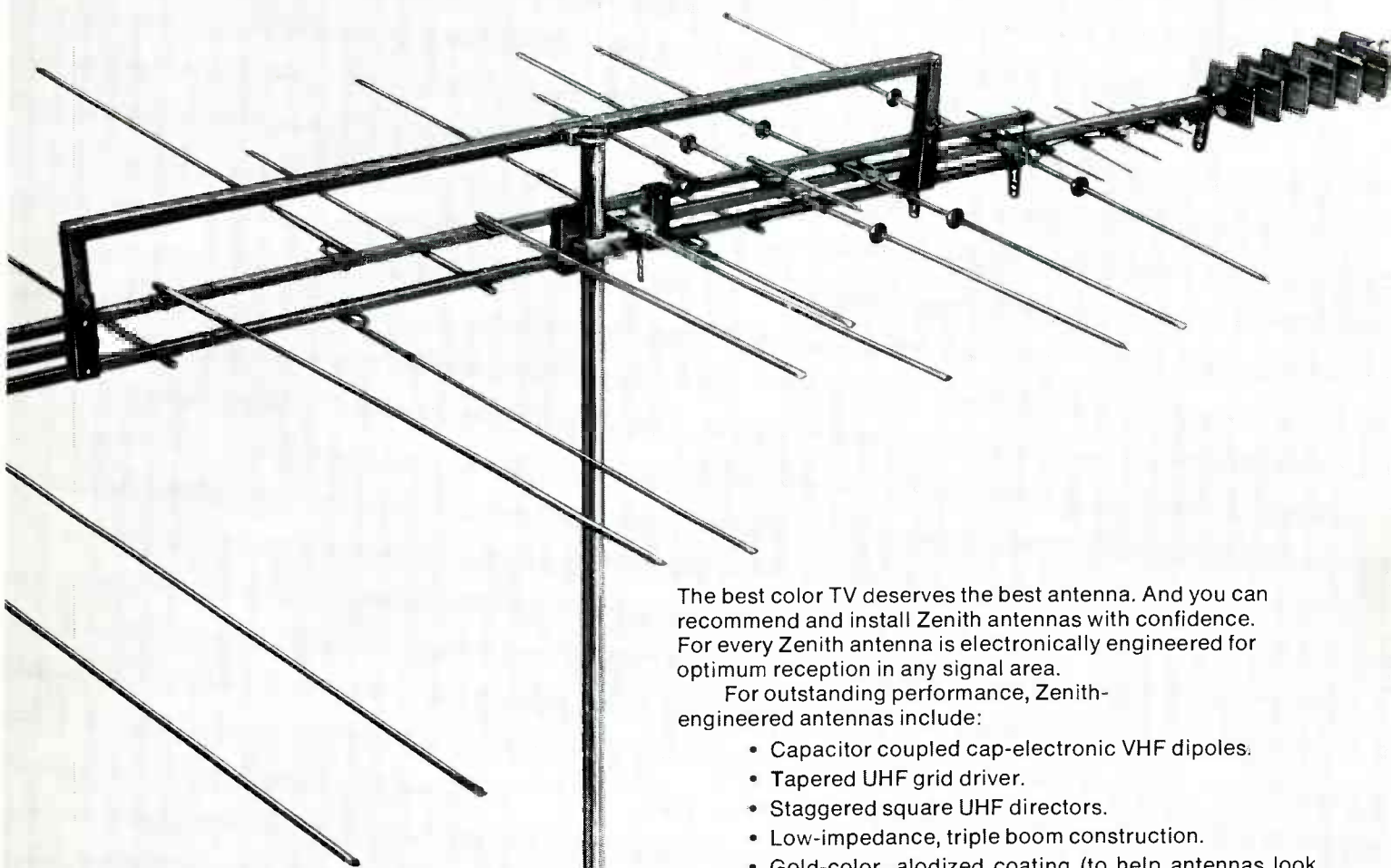
MARK OF EXCELLENCE



*Circle 29 on literature card*



# Engineered for outstanding reception— Zenith outdoor antennas for Color TV!



The best color TV deserves the best antenna. And you can recommend and install Zenith antennas with confidence. For every Zenith antenna is electronically engineered for optimum reception in any signal area.

For outstanding performance, Zenith-engineered antennas include:

- Capacitor coupled cap-electronic VHF dipoles.
- Tapered UHF grid driver.
- Staggered square UHF directors.
- Low-impedance, triple boom construction.
- Gold-color alodized coating (to help antennas look better and last longer, with greater corrosion resistance and electrical conductivity).

Your Zenith Distributor has the complete line of Zenith quality-engineered TV antennas and antenna accessories. His staff has the technical experience and knowledge of your area to recommend the best antenna for any installation.

**EXCITING SURPRISES FOR YOU—and Your Family!**  
Get the details at your Zenith *Distributor's Parts Department*.

**Why not sell the best**

**ZENITH®**

*The quality goes in  
before the name goes on*

*Circle 30 on literature card*



# Solving High Voltage Regulator

Circuit operation, trouble symptoms, troubleshooting techniques:

by Carl Babcoke

■ High-voltage and horizontal-sweep regulation are both essential for good color TV performance. The total beam current in a color picture tube is more than three times that of a b-w tube. A typical b-w receiver has a decrease of around 2KV as the brightness is changed from a black raster to a picture of normal brightness, but a color TV without any high-voltage regulation would go from around 50KV down to 25KV. Excessive high voltage can cause arcs in the picture tube or around the high-voltage rectifier socket, poor focus, flyback transformer failure, and possible X-radiation. In addition, the changing load of the varying high-voltage power in the horizontal sweep circuit will cause changing width, linearity, height, focus and convergence as the brightness varies.

As undesirable as these symptoms are, a defective regulator circuit may cause worse problems, such as compressed linearity on the left side of the raster, or even a complete loss of high voltage.

## Series vs Shunt Regulators

Both series and shunt (or parallel) types have been used in DC power supply regulators. A simplified schematic of each is shown in Fig. 1. If the output voltage decreases in the series regulator, the

feedback voltage signals the circuit to reduce the ohmic value of the series resistor enough to restore the desired voltage. The same action, but in reverse, occurs when the output voltage rises. This circuit can regulate the output voltage when the load current changes, or when the supply voltage varies. It is also economical of power since only the voltage across the control resistance is wasted. Because of the difficulties in insulation, and because the load on the horizontal sweep circuit is not stabilized, the series regulator has not been used in any color receivers.

Shunt regulation places the variable resistance used for control in parallel with the output load. If the voltage there decreases, the feedback voltage causes the regulator circuit to raise the variable resistance until the proper level of voltage is restored. Conversely, a higher output voltage causes the control resistance to decrease. The load current and regulator current always total the same.

When the shunt regulator is used in color TV, it is an excellent regulator for controlling voltage variations caused by changes in the output load current (picture tube current), but is only partially effective against line voltage changes. It also stabilizes the sweep and focus since the regulator current rises when the picture tube current is reduced, and vice versa. Varia-

tions of this circuit were used exclusively for the first 12 years of color TV manufacturing.

Two new solid-state color receivers regulate the power applied to the yoke and high-voltage transformer. They will be described later.

## Practical Shunt Regulator Circuits

The regulator circuit of the Zenith 25MC36 chassis is shown in Fig. 2. Its operation is typical of many using the 6BK4 tube. The regulator plate is connected to the DC high voltage, and the cathode is connected to the B+ supply as a reference point. B boost voltage follows quite closely the variations in high voltage, so it is brought to the regulator grid through one fixed and one variable resistor, to complete the voltage divider.

The variable resistor is used to permit precise bias and adjustments—accurate bias is very necessary since a 6BK4 with 25KV on the plate will draw 1.5 ma. at approximately -7 volts of grid bias and is cut off completely at -13.

If the brightness of the picture is reduced for any reason, the picture tube current decreases, causing the high voltage to rise. The B boost also rises since the sweep circuit load is less, the 6BK4 grid becomes more positive and the plate draws more current to reduce the

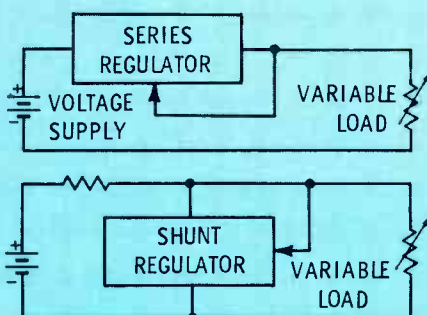


Fig. 1 Two basic types of DC voltage regulators.

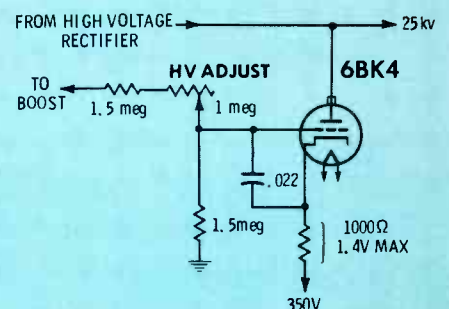


Fig. 2 High-voltage regulator circuit employed in Zenith 25MC36 chassis.

# Problems

high voltage. This sequence is reversed when the brightness is increased.

The Motorola TS908 chassis has a voltage-sensitive resistor (VDR or varistor) between B boost and the high-voltage control (see Fig. 3) to transfer to the grid more of the change in the boost voltage. This reduces the variation in high voltage during brightness changes.

Fig. 4 shows a circuit variation used in the RCA CTC15 chassis (and all later models with a 6BK4) in which has been added a 12-megohm resistor from the picture tube cathodes to the 6BK4 grid. Large, bright areas of the picture or a higher setting of the brightness control will lower the voltage at the picture tube cathodes and, through the 12-megohm resistor, slightly decrease the 6BK4 grid voltage. This increases the grid bias and reduces the regulator plate current more than the usual amount. Demonstration of this action can be made if you start with the brightness control counterclockwise and turn it slowly clockwise while you watch the reading of the high-voltage meter. The high voltage will increase as the screen brightens. Above a certain brightness level, further increase causes a small reduction in the high voltage. If the brightness is kept below the blooming point, the high voltage often will not vary more than about 200 volts.

The capacitor from the grid of

the regulator tube to cathode (or B boost, according to model) is to eliminate overcorrection and the "hunting" which will result if the grid voltage is permitted to change too rapidly.

Adjustment of these shunt regulators is quite simple: turn the brightness control down completely (also color control if color is seen) and adjust the high-voltage control for the correct regulator current according to the voltage drop across the 1K cathode resistor. Just remember that 1 volt = 1 ma., 1.4 volts = 1.4 ma., etc. If you don't know what current is recommended, use this rule of thumb: a 1957 model should be set for about .9 ma. and large screen sets of 1965 or later models for 1.4 ma. Smaller screen chassis should be adjusted for about 1.2 ma. Other models between these ages can have the current approximated since the older the model, the smaller the current.

Some manufacturers specify that the high-voltage control should be adjusted for a certain voltage at the picture tube when the brightness control is turned to produce a black raster. This is not as accurate as the regulator-current method. Suppose the horizontal sweep circuit is weak or the line voltage is low. The high voltage may reach the specified value only with little or no regulator current. If the 6BK4 current is only .4 ma., the high voltage regulation would be effective

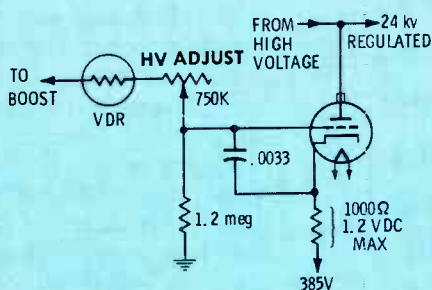
only until the picture tube current also reached .4 ma. Above that point, the regulator is cut off and ineffective. Any increase in brightness would cause the high voltage to drop and the picture to bloom. The only satisfactory method is to measure both high voltage and regulator current under varying brightness conditions.

## Troubleshooting High-Voltage Shunt Regulators

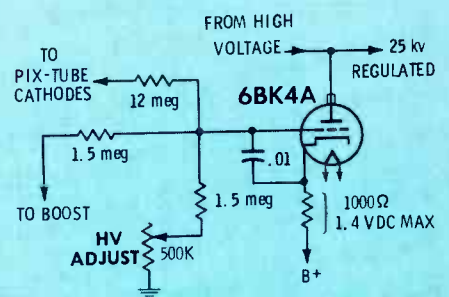
A rapid and accurate diagnosis that indicates whether the horizontal sweep or the regulator is at fault can be made if you attempt to adjust the high voltage while you measure the regulator current and the high voltage. Here is the sequence:

1. Turn down completely the brightness and color controls.
2. Set the "HV Adjust" control for the recommended voltage across the regulator cathode resistor.
3. Turn the brightness control up slowly while you watch the cathode resistor voltage.
4. The reading should drop down slowly and smoothly as the brightness is increased.
5. No blooming should be seen on the screen until the cathode resistor voltage is zero, then further brightness increase should cause de-focusing, loss of some width on the left, and a taller picture. This

**Fig. 3** Voltage-dependent resistor (VDR) is added to basic regulator circuit in Motorola TS908 chassis.



**Fig. 4** A resistor for extra video control of regulation is added to most RCA regulator circuits employing 6BK4.



Is normal blooming, according to the conditions specified.

6. Connect a high-voltage probe and meter to the picture tube anode and notice the voltage as you vary the brightness. At moderate brightness, the voltage should be within  $\pm 1KV$  of the amount specified in the PHOTOFACT. Also, the voltage should not change more than about 500 volts as the brightness is varied from minimum to just under the blooming point.

Any receiver that passes this test must be considered as having completely normal high voltage and high-voltage shunt regulation.

But what of the sets that flunk these adjustments and measurements? Let's go over again in greater detail some of the steps in the previous adjusting sequence:

2. The accuracy of the regulator current reading depends on the exact value of the 1K cathode resistor. Many of these resistors have been overloaded by shorted or gassy regulator tubes until they are completely out of tolerance or have even been burned in two. Check each resistor visually and with an ohmmeter. When the "HV Adjust" control will not produce adequate voltage across the cathode resistor,

these defects should be suspected:

- A. A weak regulator tube if the high voltage is too high, or a weak high-voltage rectifier if high voltage is low but B boost is normal.
- B. The total resistance from B boost to the grid may have raised in value.
- C. If the high voltage and B boost are both low, the horizontal sweep circuit is weak; check the damper and horizontal output.

Check these possibilities if the regulator cathode current cannot be adjusted low enough:

- A. The capacitor from grid to cathode (or B boost) may be leaky or shorted.
  - B. The resistor (or resistors) from grid to ground may have increased in value.
  - C. The regulator tube may be shorted or gassy.
  - D. The line voltage may be too high.
4. Leakage of the grid capacitor should be suspected if the current does not decrease normally.
  5. If blooming should occur before the regulator current reaches .2 ma (.2 volt), the picture tube current is increasing more than the regulator is

decreasing. Check all the grid resistors and the grid capacitor carefully and substitute the regulator tube (it might be slightly weak).

Have you ever had a set owner tell you the picture was brighter before you adjusted the high voltage? If the receiver adjusts correctly according to the 6 steps in the procedure (especially steps 5 and 6), you can positively assure that customer that the brightness seen just below the blooming point is the maximum the set was designed to produce. An opinion based on anything else is merely guesswork.

Remember these tips:

1. Correct regulator current is more important than any specified high voltage, although the voltage should be within  $\pm 2KV$ .
2. Excessive regulator current will narrow the picture on the left side and probably cause an early failure of the tube.
3. Too much high voltage will cause arcs and may cause X-radiation.
4. Make certain the voltage does not rise above 27KV with any levels of brightness.

#### Adjustment Without Meters

There are two ways of estimating regulator action: 1) Watch the picture carefully as you adjust the brightness from dark to the point of blooming; there should be very little change in width or focus until blooming starts, then they should change rapidly. 2) Regulator plate glow, when the brightness is turned down, can be used as a rough indication of regulator current, although the newest tubes tend to have a faint greenish color instead of the bright orange glow of the older ones.

#### Pulse Regulators

Other color receivers regulate the high voltage and sweep with a shunt regulator which maintains a constant load on the flyback transformer. When the current through the high-voltage rectifier is large, the regulator current is small, and vice-versa. The loading effect on the flyback is the same, so the sweep and AC high voltage (before rectification) are regulated.

Two examples of this type will be explained. Fig. 5 gives the sim-

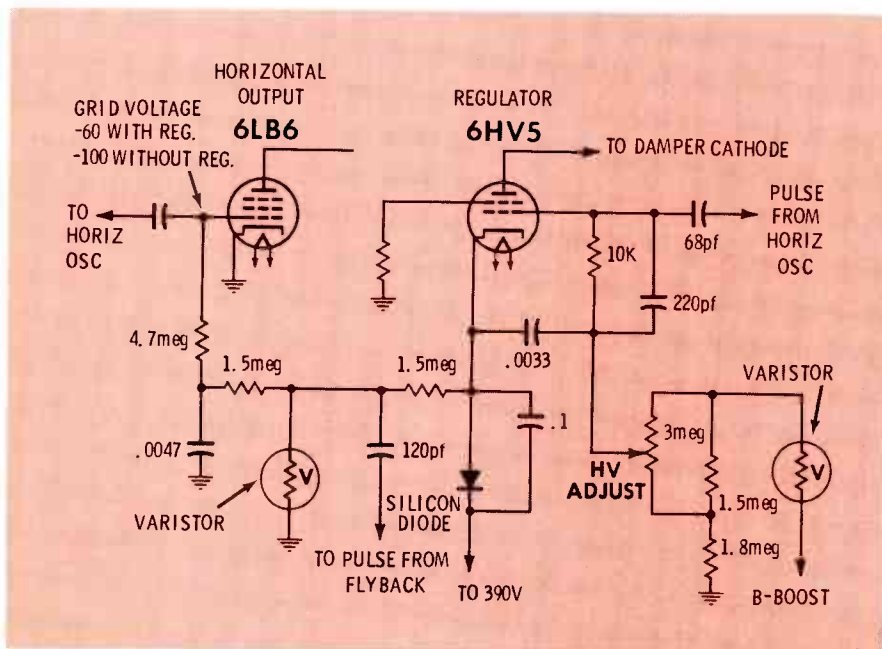


Fig. 5 Shunt-pulse regulation is employed in the Zenith 14A9C51. The diode in the cathode circuit of the regulator reduces the sweep and high voltage if the regulator fails.









ings, transistor or Zener, etc.) also will increase the high voltage and sweep.

### Emergency Regulator Systems

Arcs, flyback failures and possible X-radiation may result from excessive DC high voltage (above 27-KV). Many manufacturers are adding auxiliary protection circuits that will reduce both sweep and high voltage if the regulator draws no current. One such circuit was a part of Fig. 5, and it operates in the following manner: If the 6HV5 does not conduct, the silicon diode connected between cathode and B+ opens. This removes the +390 volts from the 1.5-megohm resistor. The flyback pulse, applied through the 120-pf capacitor, is rectified by the varistor to produce negative voltage which is filtered and added to the 6LB6 grid. This reduces the sweep and high voltage. The best clue to a non-conducting regulator is the 6LB6 grid voltage, which rises from the normal -60 volts to over -100 volts when the regulation fails.

Late production RCA CTC38 chassis also have a diode-operated protection circuit, shown in Fig. 9. During normal operation, when the 6BK4 draws current, the diode is forward biased and is nearly a short circuit. The grid of the 6LQ6 horizontal output tube has applied to it a negative voltage from grid rectification of the horizontal oscillator sawtooth, and negative voltage from the grid of the blanker (-85 to -90 volts), which is balanced out by the positive voltage coupled through the 8.2-megohm resistor from the +405 volts present at the cathode resistor of the 6BK4.

If the 6BK4 cathode current drops to zero, the diode is reversed-biased so that it becomes an open circuit, and the voltage at the diode anode is reduced to nearly zero. The positive voltage that formerly was present at this point is canceled, and only the negative voltage from the blanker is applied to the horizontal output tube grid. Because of this negative voltage on the grid of the horizontal output tube, the high voltage cannot rise above 24 KV under any brightness condition.

Troubleshooting the receiver after this fail-safe circuit action has occurred can be very puzzling. The screen symptoms are as follows:

#### RC144 HANDY "36" —

Has the 36 most often used components for substitution: gives you 24 ½-watt and 1-watt resistors from 10 ohms to 5.6 megohms; 10 capacitors from 100 mfd to 0.5 mfd at 600 volts; and 2 electrolytics at 10 mfd and 40 mfd at 450 volts DC.  
**only \$17.95**

#### RC145 HANDY "53" — provides

same resistors and capacitors as in Handy "36" above plus a full range of electrolytics from 2 mfd to 250 mfd at 450 volts DC; for use singly or as duals for direct, fast substitution. Exclusive current surge protector to protect both circuit and operator.  
**All for only \$34.95**

#### RC146 HANDY "75" —

top-of-the-line unit provides 75 frequently used values for fast, on-the-spot substitution: 12 1-watt resistors from 10 to 5.6k ohms; 12 ½-watt resistors from 10k to 5.6 megohms; 10 600-volt capacitors from 100 mmfd to 0.5 mfd; 10 electrolytics used singly or as duals to form up to 25 different values, 2 mfd to 250 mfd at 450 volts DC; exclusive electrolytic surge protector circuit; power resistors of 20 watts from 2.5 to 15,000 ohms; universal 0.5 amp silicon and selenium rectifier.  
**Deluxe buy, only \$49.95**



**when  
you're busy  
as a  
Beaver**

### GET HELP FROM SENCORE SUBSTITUTION UNITS

Your time is way too valuable to waste it hunting up parts for substitution testing, wiring them in, unsoldering, and putting them away all messed up!

**Save that time!** — with a Sencore substitution unit. You can buy one complete for less than the cost of the parts alone.

See your Sencore distributor today



**SENCORE**

NO. 1 MANUFACTURER OF ELECTRONIC MAINTENANCE EQUIPMENT

426 SOUTH WESTGATE DRIVE, ADDISON, ILLINOIS 60101

Circle 31 on literature card



At low brightness the picture is badly narrowed on the right side of the screen and is defocused. As you turn the brightness control up, the picture gets wider and focus improves, but it is not completely normal, even there.

The 6LQ6 grid voltage normally should be around -58 volts. With no 6BK4 regulation and with the brightness low, the grid voltage will be approximately -73, and at high brightness will drop to about -64.

The tip-off to this trouble is the increased variation of the 6LQ6 grid voltage, which normally changes very little with different levels of brightness. Make the 6BK4 regulation operate correctly and the other trouble symptoms should disappear.

### Summary

Regulation of horizontal sweep and high voltage are just as important as in the past, but now there are several basic types of regulating systems, each with different requirements for efficient operation.

We strongly advise all technicians to use a good high-voltage probe to make certain that the high-voltage and sweep regulation of each color set is proper. ▲

## GET COMPLETE DETAILS

about the products  
advertised or described  
in this issue.



Use Free  
Reader Service Card.

Be sure to include  
your name and address

# antenna systems report

### Dome-Type TV Antenna

Called the Vorta Omni Mark II, this new outdoor TV antenna consists of 93 feet of aluminum coil integrated into what is termed the "Vorta" system design. The whole assembly is housed beneath an 18½-inch by 8-inch plastic dome that is completely free of exterior metal parts.



According to the distributor of the new antenna, Omni Electronics, it compares favorably to other antennas in signal-strength tests measured over a 50-mile radius, and a year of tests on homes in the U.S., England and Germany have proved the antenna to be "sensitive to reception regardless of signal direction," according to the distributor.

The new antenna is guaranteed for five years and is priced at less than \$50.00.

Circle 54 on literature card

### VHF-TV/FM Antenna System Amplifier

This FINCO fully-transistorized 4-outlet VHF-TV/FM Amplifier (Model M-101) can be placed in any convenient location—attic or roof space, garage wall or screwed to a joist in the basement at a point where the antenna lead-in usually enters. From the four pairs of marked terminals, suitable lengths of 300-ohm lead-in can be run to the living room, recreation room, den, bedroom, patio or any other area desired.

New home building plans should include locating the amplifier in the roof space underneath the antenna



and running the 300-ohm lead-in through the studding to the specified rooms, terminating them permanently in a wall plate.

With a gain of 6 dB to each of the four outputs, the amplifier will supply to each outlet a signal approximately 50% greater than that at the antenna. Each receiver may be tuned separately to any channel normally received in the area. In addition, the fourth outlet can be used to feed an FM receiver.

Model M-101 is priced at \$42.50.

Circle 55 on literature card

### Feed-Thru Wall Plate

The new Mosely Feed-Thru Wall Plate has a single hole versatile enough to accept TV coax, telephone line, audio speaker line, rotor lead-in or any other circular cable or wire with up to ½-inch outside diameter.

The unit can be mounted on most wall surfaces or standard AC outlet boxes and is colored ivory.

Model M-1 comes with mounting screws and is priced at 42 cents; Model M-1PK comes complete with two wood screws, toggle bolts and Mosley F-9 brackets, and is priced at 86 cents. ▲

Circle 56 on literature card

# photofact<sup>TM</sup>bulletin

PHOTOFACT BULLETIN lists new PHOTOFACT coverage issued during the last month for new TV chassis. This is another way ELECTRONIC SERVICING brings you the very latest facts you need to keep fully informed between regular issues of PHOTOFACT Index Supplements issued in March, June, and September. PHOTOFACT folders are available through your local parts distributor.

<b>BRADFORD</b>	DMAT-89391 .....	1034-1
<b>CORONADO</b>	TV2-6622A .....	1034-2
<b>EMERSON</b>	7P50 .....	1036-1
<b>MAGNAVOX</b>	Chassis T938-01-AA, T938-01-AB .....	1037-1
<b>MOTOROLA</b>	Chassis 20TS-/21TS-/C21TS-/ 22TS-612A .....	1035-1
	Chassis C16TS-597, 16TS597 .....	1036-2
<b>NIVICO</b>	3310 .....	1033-1
	7208 .....	1035-2
<b>OLYMPIC</b>	Chassis CTC30 .....	1033-2
	AM-FM-FM Stereo Chassis 323/MX12 .....	1033-2A
<b>PENNCREST</b>	4888-46, 4891-49, 4892-47 ....	1036-3
<b>SHARP</b>	SQ-46P .....	1034-3
<b>WARDS AIRLINE</b>	GHJ-17529A/B, -17549A/B, 17559A/B, -17829A/ 49A/59A .....	1037-2

## Got a Troubleshooting Tip?

If you've recently run across an unusual trouble symptom and have determined what caused it, why not pass the info on to the other readers of ELECTRONIC SERVICING. You'll not only be saving other service technicians valuable troubleshooting time, you'll also be making a little extra change for yourself. Send a thorough description of the trouble symptom and the solution along with a brief discussion of your troubleshooting technique to:

**Troubleshooting Tip, ELECTRONIC SERVICING**  
1014 Wyandotte Street,  
Kansas City, Missouri 64105

## bookreview

### How to Use Grid-Dip Oscillators:

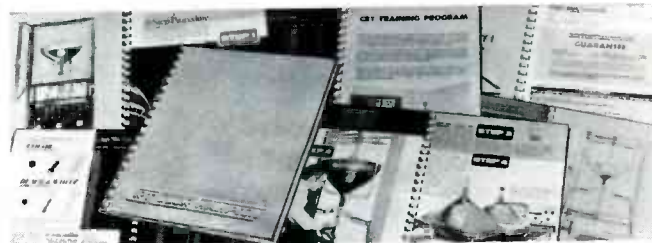
Rufus P. Turner, Rider series, Hayden Book Co., Inc., New York, revised second edition, 1969; 111 pages, 5¼" x 8¼", paperbound, \$2.95.

A handbook outlining practical applications of the grid-dip oscillator in testing radio, television and communications equipment. Included are step-by-step instructions on how to measure inductance, test and align TV and how to determine the resonant frequency of an antenna or check for proper antenna loading.

This text also describes how to use the grid-dip oscillator as a field-strength meter, a signal source for an SWR meter, and an RF meter.

A roundup of currently available assembled and kit-form grid-dip oscillators is presented in the final chapter. ▲

## FREE CATALOG



## RT COLOR CHAMPION

### TV PICTURE TUBE REBUILDING EQUIPMENT

C.R.T. Equipment Company, Inc.  
2740 Old Lebanon Road  
Nashville, Tennessee 37214

Telephone (615) 883-0215

### Mail Coupon Today

(Please Print)

Name \_\_\_\_\_

Firm Name \_\_\_\_\_

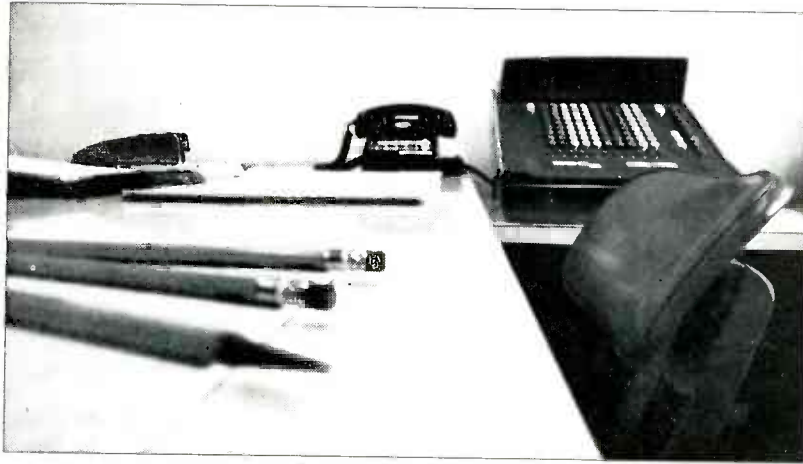
Address \_\_\_\_\_

City \_\_\_\_\_ State \_\_\_\_\_ Zip \_\_\_\_\_

### Clip Me Out

Circle 32 on literature card

# The skilled labor shortage.



## It's amazing how fast you could change it.

Lots of companies don't have a skilled labor shortage at all. They've done something about it.

They've turned workers into skilled workers.

You can end your skilled labor shortage, too.

In a few months. Train the unskilled.

How long does it take to train a man to be a welder, machinist, bookkeeper, draftsman, assembler, molder? A few months. That's all.

Those unskilled Whites, Negroes, Puerto Ricans,

Mexican-Americans and others are a source of talent to end any labor shortage. And end it for good.

350 corporations think so. They've formed a voluntary organization called Plans for Progress.

They've got a lot of ideas about equal job opportunity and how it benefits you. Let them tell you what they think. Write:

Plans for Progress, 1800 G Street, N.W., Suite 703, Washington, D. C. 20006.



Things are changing. In the next 5 years, 8,000,000 good jobs will open up for Whites, Negroes, Puerto Ricans, Mexican-Americans, everyone.



**NEW BERN'S PERFECT PIN CRIMPER**

### Picture-Tube Repair Tool

Also for—5U4, 6SN7, 6BQ6, etc.

Eliminates that hard soldering job

only \$1.69 each

**A MUST for round color pic tubes**

PT-1  
3/32" PIN

Fix loose pin connections in seconds. Pays for itself in time saved on first job. Less than 3" long. Carry it in your pocket.

Patented

Intermittent operation of picture tubes and other tubes due to defective solder connections easily corrected. Provides solid electrical connections, can also be used as channel-selector wrench and screwdriver. Pin keeps its original form. A 3-in-1 tool.

**3 MODELS ELIMINATE SOLDERING**

Makes Solid Electrical Connections

### Phono Pin-Plug Crimper

Slip wire in "pin plug," insert in tool, and squeeze... job is done.

AU-2  
1/8" PIN

C-Rings  
3 for 5¢

Use end of tool to push on C-ring for ground connection.

Ant. plugs, hi-fi, multiple plugs, public address, radio and TV tubes, radar, speakers, and loop connections. Many, many more uses.

Model LC-3 for 5/32" pin diameter

At your parts distributor, or write us

**BERN'S MANUFACTURING CO.**  
60000 KUNSTMAN  
WASHINGTON, MICH. 48094

Circle 33 on literature card

## productreport

for further information on any of the following items, circle the associated number on the reader service card.

### Alignment Tool Set

A new, seven-piece alignment tool set designed for use in TV and AM and FM radios has been announced by JW Electronics. The set, Kit PA68, consists of the following tools: a .078 hex stopper type with flexible shank; a .078 hex stopper type with rigid shank; a



.078 hex through type; a .101 hex stopper type; a .101 hex through type; a .101 non-magnetic, metal-tipped, insulated, oscillator screw adjusting tool (double-ended); and a .025 x .156 tip non-metallic trimmer adjuster with a non-metallic conical-point probe. All tools in the kit are made of glass-filled polymer plastic.

The kit is priced at \$2.95 (minimum order of 5 kits). Individual tools in the kit are available in quantities of 100 or more.

Circle 50 on literature card

### Blue Lateral and Purity Assembly

J. W. Miller introduces the single unit Miller 7604 blue lateral and purity assembly for any size American rectangular color picture tube.

The unit registers blue, red and green beams simultaneously within .06 inch. A single wheel rotates two magnetic rings in opposite directions to provide blue beam lateral convergence.

## INTRODUCING

### The Ultimate In Tuner Washes..



BLUE SHOWER washes and degreases all tuners—safely and quickly because BLUE SHOWER is 30% more powerful than other cleaners of this type — literally floods away the dirt and contamination that caused tuner drift and trouble for you. BLUE SHOWER leaves no residue and can't contaminate even the most sensitive parts of the tuner such as neutralizing and RF coils. After using BLUE SHOWER we recommend treating the contacts with BLUE STUFF FOR TUNERS which will clean the contacts each time the channel is changed.

### SPECIAL INTRODUCTORY OFFER

Buy 1 can of BLUE SHOWER  
and 1 can of BLUE STUFF  
and get a second can of  
BLUE STUFF — — — — FREE  
Offer good for a limited time at  
participating jobbers everywhere

**TECH SPRAY**

Box 949 Amarillo, Texas 79105  
Canada: Wm. Cohen, Montreal  
Export: Singer Products NYC

Circle 35 on literature card

June, 1969/ELECTRONIC SERVIC

After just 1 year it's THE INDUSTRY STANDARD



BLUE STUFF, the one that doesn't just foam and fizzle out — the thick coating cleans, polishes and re-lubricates each time the channel is changed.

**TECH SPRAY**

Box 949 Amarillo, Texas 79105  
Canada: Wm. Cohen, Montreal  
Export: Singer Products NYC

Circle 34 on literature card

(continued)



Purity correction is accomplished by individual adjustment of the two purity rings. The magnets compensate for misregistration up to .005 inch in any direction.

Each unit costs \$3.96.

Circle 51 on literature card

### Personal Portable TV Tube Britener

As of July 1, Model C-414, a TV tube britener by Perma-Power, will be available nationwide. Nu Brite, used with miniature base (7G4)



tubes, brightens pictures on AC-operated sets and series-wired TV sets with 4.5- and 6.3-volt picture tubes, but not on battery-operated sets utilizing a 12-volt picture tube. List price is \$3.35.

Circle 52 on literature card

### Bench Assembly Station

A new bench model assembly station is announced by Henry Mann, Inc., for efficient locating of small electronic parts. This 36-inch long unit contains 32 (DL-20) poly-



propylene stack bins which can be stacked and locked on top of each other without a master holding fixture. Each bin measures 7 $\frac{3}{8}$  inches long by 3 $\frac{7}{8}$  inches wide by 2 $\frac{7}{8}$  inches high and comes in red, blue, yellow and green for easy parts and component identification. Prices range from \$9.50 to \$195 according to size. ▲

Circle 53 on literature card

### Moving?

Send your new address to:

**ELECTRONIC SERVICING**

Circulation

1014 Wyandotte St.

Kansas City, Missouri 64105

## Zenith "Royal Crest" Tubes... with unrivaled dependability

Zenith "Royal Crest" replacement circuit tubes are engineered to the same exacting standards as original Zenith circuit tubes in new sets. With the same unrivaled dependability and "new set" performance.

Zenith "Royal Crest" circuit tubes are life-tested under actual operating conditions for more than 1,500,000 hours every month!

The "Royal Crest" line is broad and comprehensive. Over 900 different types, all built to Zenith rigid quality standards.

Insist on Zenith quality. Choose Zenith's "Royal Crest" circuit tubes and assure customer satisfaction.

**EXCITING SURPRISES FOR YOU—and your family!**  
Get the details at your Zenith Distributor's Parts Department.

Don't sell the best



The quality goes in  
before the name goes on



Circle 36 on literature card

105  
Ireel  
NYC

ING 65



ATR Electronics Inc. ....	36
AT&T .....	23
B & K Mfg. Co. ....	1, 68
Berns Mfg. Co. ....	65
Borden Inc., Chemical Div.- Krylon .....	29
Bussmann Mfg. Div. McGraw-Edison Co. ....	7
CRT Equipment Co. ....	63
Cleveland Inst. of Electronics ....	33-34, 35
Cornell Dubilier Electronics .....	Cover 2
Delco Radio Div. General Motors Corp. ....	53
Enterprise Development Corp. ...	36
The Finney Co. ....	19
General Electric Co. Tube Div. ....	27
Heath Co. ....	10
Lectrotech, Inc. ....	4
Littelfuse, Inc. ....	Cover 4
Multicore Sales Corp. ....	42
Precision Tuner Service .....	9
RCA Electronic Components Distributor Products .....	49
RCA Electronic Components Test Equipment .....	15
RCA Electronic Components Picture Tube .....	Cover 3
RCA Institutes, Inc. ....	11
RCA Sales Co. ....	21
RMS Electronics Inc. ....	42
Rohn Mfg. Co. ....	43
Howard W. Sams & Co., Inc. ....	39
Sencore, Inc. ....	37, 61, 67
South River Metal Products Co., Inc. ....	6
Sprague Products Co. ....	3
Sylvania Electric Products, Inc. ....	41
Tech Spray .....	65
The Triplett Electrical Inst. Co. ....	8
Tuner Service Corp. ....	5
Weller Electric Corp. ....	25
Xcelite, Inc. ....	32
Zenith Sales Co. ....	55, 66

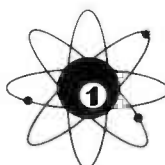
# LOOKING FOR ACCURACY?



## STOP RIGHT HERE!

Take a close look at a revolutionary new multimeter. The Sencore Field Effect Meter. This beautifully styled FE meter virtually obsoletes all VTVMs and VOMs. Why? Exclusive FET circuitry. A totally new concept in multimeter design that prevents circuit loading. Interested? Here's more. The FE16's 15 megohm input impedance on DC and 10 megohm on AC is 750 times less loading than a standard 20,000 ohm/volt VOM, 50% less loading than a standard VTVM on DC volts and 10 times less loading on AC volts. Here's a real package of dynamite that means accuracy. FET ACCURACY that's 1.5% on DC, 3% on AC. (An unbelievable 1/2% full scale accuracy on 1 VDC.)

Want more? Look a little closer. An exclusive true zero center scale starting at  $\pm .5V$  DC, DC current ranges from  $100\mu A$  to 1-amp, complete meter and circuit overload protection, mirror back scale, built-in battery check, rugged vinyl clad all steel case, and . . . that's it. If you still want a closer look, you'll have to buy it. Remember the name **FIELD EFFECT METER**. Only Sencore makes them. Your Distributor has them in stock at \$84.50—less than the cost of a good VOM or VTVM.



### SENCORE

NO. 1 MANUFACTURER OF ELECTRONIC MAINTENANCE EQUIPMENT

426 SOUTH WESTGATE DRIVE, ADDISON, ILLINOIS 60101

Circle 37 on literature card

June, 1969/ELECTRONIC SERVI



**ANTENNAS**

100. *JFD Corp.*—8-page illustrated brochure, Form 12-1030, describes new kits for outlet expansion and home amplifiers for city, urban, weak signal and fringe areas, specifications included.

**AUDIO**

101. *American Gelo*—8-page illustrated brochure offers engineering data and specifications on entire line of microphones and accessories, including new unidirectional microphone.
102. *Craig Corp.*—Illustrated folder describes full line of sound entertainment products including cassette and reel recorders and accessories, home and mobile cartridge players.
103. *Ercona Corp.*—Complete il-

lustrated cross reference guide contains available styli numbers featuring new Omega replacement styli.

104. *Robins Corp.* — 24-page c6900 catalog lists magnetic recording tape and audio accessories ranging from cassette and reel tape to devices for tape editing, mailing, storage and machine care.

**COMPONENTS**

105. *Alco*—20-page Alcoswitch catalog gives specifications, dimensional drawings and prices of products featuring expanded line of miniature electronic switches and keyboard assemblies.
106. *Erie*—32-page distributor catalog full of diagrams and charts contains all electronic components in stock.
107. *Landsdale*—New catalog lists prices of over 400 current and discontinued PNP and NPN silicon and germanium transistors.

**SPECIAL EQUIPMENT**

108. *Grif-Stik*—Brochure gives prices and explains uses of magnetic plastic signs.
109. *Seton Corp.*—Catalog 69-B supplies data and prices on large varied selection of Seton property identification tags.
110. *W. H. Brady Co.*—24-page catalog of 6,000 stock items introduces many new wire marker products.

**TECHNICAL PUBLICATIONS**

111. *Howard W. Sams*—Literature describes popular and informative publications on radio and TV servicing, communication, audio, hifi and industrial electronics, including 1969 catalog of technical books on every phase of electronics.

**TEST EQUIPMENT**

112. *Pomona*—52-page 1969 general catalog lists 375 electronic accessories with photos, dimensional drawings, specifications, features and complete engineering information including typical applications. ▲

# Image Builder.



**B&K 1245**  
**Station Quality**  
**Color Generator**

Thanks to color television, you're working in a vastly expanded market. It's highly competitive; and you have to do a first-rate job to stay on top of your competition. That's why B&K developed the 1245 Color Generator. It's the "Silent Partner" that makes a good impression. One that sells your customer on you and builds your image as a top-notch professional technician.

The B&K 1245 Portable Color Generator is the leader in the service industry. No other color generator on the market can compare in quality and performance.

All solid-state, the 1245 offers instant operation in all service environments. Eliminates waiting, warm-up, or adjustment. And you receive the most, cleanest patterns possible.

Portable, the 1245 has only three control knobs for ease of operation. Control color level and

pattern selector. Station-quality waveforms provide complete protection against obsolescence. A well-defined back porch on the horizontal sync pulse makes it easier to converge the color tube. And the built-in gun killer works on any picture tube, both foreign and domestic.

So if you're looking for a portable color generator that can solve color servicing problems fast, the B&K 1245 is your answer. It's not just a color generator. It's a "Silent Partner," designed to give you more time to create new sales by cutting servicing time to a minimum.

**B&K Color Generator.**  
**Model 1245. Net: \$134.95.**

*B&K Division of Dynascan Corp.*  
1801 W. Belle Plaine  
Chicago, Illinois 60613

Send to test equipment.  
B&K Silent Partners.



Circle 38 on literature card

CING 67

SERVICING/June, 1969

# Confidence builder RCA HI-LITE color picture tubes

When does a component contribute more to a service call than simply the solution to your customer's problem? *When it also contributes to your service reputation!* Such is the case with HI-LITE picture tubes where RCA's experience in Color TV truly shows its hand.

When you install a HI-LITE replacement picture tube you know . . . and your customers can be told . . . that here is the same quality . . . the same tube . . . that goes into original equipment sets. That it's all new — glass, gun, the works! And that it incorporates the latest technical advancements of the world's most experienced color picture tube manufacturer, such as PERMA-CHROME and Unity Current Ratios. All this . . . plus the broadest line of types in the industry.

See your Authorized RCA Distributor for your tube needs. Install the brand that instills confidence.

RCA Electronic Components, Harrison, N.J.

# RCA



# Introducing a Complete Line of Littelfuse Quality Circuit Breakers



Actual Size  
1 3/4" x 1 3/16" x 1/2"

## Exact replacement from factory to you

Designed for the protection of television receiver circuits, the Littelfuse Manual Reset Circuit Breaker is also ideally suited as a current overload protector for model railroads and power operated toy transformers, hair dryers, small household appliances, home workshop power tools, office machines, small fractional horsepower motors and all types of electronic or electrical control wiring.

# LITTELFUSE

DES PLAINES, ILLINOIS

Circle 40 on literature card

IA 80 413 571

SAMUEL SACHS  
809 BERGEN ST.  
PHILADELPHIA, PA. 19111